

BGS COLLEGE OF ENGINEERING AND TECHNOLOGY

DEPARTMENT OF MECHANICAL ENGINEERING

Mahalakshmi layout, Bengaluru- 560086



INTRODUCTION TO MECHANICAL ENGINEERING (BESCK104D/204D)

MODULE - 01

Syllabus: Module-1

Introduction: Role of Mechanical Engineering in Industries and Society- Emerging Trends and Technologies in different sectors such as Energy, Manufacturing, Automotive, Aerospace, and Marine sectors.

Energy: Introduction and applications of Energy sources like Fossil fuels, Nuclear fuels, Hydel, Solar, wind, and bio-fuels, Environmental issues like Global warming and Ozone depletion

.....

Introduction:

Mechanical engineering is an engineering branch that combines engineering physics and mathematics principles with materials science, to design, analyze, manufacture, and maintain mechanical systems. It is one of the oldest and broadest of the engineering branches. The mechanical engineering field requires an understanding of core areas including mechanics, dynamics, thermodynamics, materials science, structural analysis, and electricity. In addition to these core principles, mechanical engineers use tools such as computer-aided design (CAD), computer-aided manufacturing (CAM), and product lifecycle management to design and analyze manufacturing plants, industrial equipment and machinery, heating and cooling systems, transport systems, aircraft, watercraft, robotics, medical devices, weapons, and others. It is the branch of engineering that involves the design, production, and operation of machinery.

Mechanical engineering field has continually evolved to incorporate advancements; today mechanical engineers are pursuing developments in such areas as composites, mechatronics, and nanotechnology. It also overlaps with aerospace engineering, metallurgical engineering, civil engineering, structural engineering, electrical engineering, manufacturing engineering, chemical engineering, industrial engineering, and other engineering disciplines to varying amounts. Mechanical engineers may also work in the field of biomedical engineering, specifically with biomechanics, transport phenomena, bio mechatronics bio nanotechnology, and modelling of biological systems.

Role of Mechanical Engineering in Industries and Society:

Mechanical Engineering is considered to be the oldest branch of engineering, which has contributed to several innovations. There is a wide scope after completion of this course.

Mechanical Engineers are instrumental in designing efficient motor vehicles, aircrafts, manufacturing units, and industrial machinery. They also contribute to the development of complex machinery systems, engines, and power equipment. Their job responsibility includes the designing, manufacturing, maintenance, and testing of this equipment.

What is Mechanical Engineering?

Mechanical Engineering is a branch of engineering that combines physics, mathematics, and engineering principles with materials science. This field aims at designing, analyzing, manufacturing, and maintaining mechanical systems. Mechanical Engineering is considered to be the broadest and the oldest of the engineering disciplines. This branch focuses on the core areas that include thermodynamics, mechanics, dynamics, structural analysis, electricity, and materials science.

These core principles are combined with tools such as CAD (computer aided design) and CAM (computer aided manufacturing) and product life cycle management for the design and analysis of industrial equipment, machinery manufacturing plants, transport systems, robotics, medical devices, heating and cooling systems and so on. This branch of engineering is primarily concerned with the design, production and operation of machinery.

This field emerged in the 18th century during the Industrial Revolution and has been continuously developing and advancing since then.

Mechanical Engineering is important because it introduces and helps implement useful technology in our day to day lives and in modern society. It has a very crucial role to play in manufactured technologies, right from refrigerators to cars to aero planes and much more.

ROLE OF MECHANICAL ENGINEERING IN INDUSTRIES AND SOCIETY

Role of Mechanical Engineering in Industries

Knowledge of Mechanical Engineering in the industry helps to do the following

- Analyze problems to see how mechanical and thermal devices might help solve a particular problem
- Design or redesign mechanical and thermal devices or subsystems, using analysis and computer-aided design
- Investigate equipment failures or difficulties to diagnose faulty operation and recommend remedies

- Develop and test prototypes of devices they design
- Analyze the test results and change the design or system as needed
- Oversee the manufacturing process for the device

Mechanical engineering is one of the broadest engineering fields. Mechanical engineers design and oversee the manufacture of many products ranging from medical devices to new batteries.

Mechanical engineering is required for the design of power-producing machines, such as electric generators, internal combustion engines, and steam and gas turbines, as well as power-using machines, such as refrigeration and air-conditioning systems.

With knowledge of Mechanical engineering, one can design other machines inside buildings, such as elevators and escalators. They also design material-handling systems, such as conveyor systems and automated transfer stations.

Like other engineers, mechanical engineers use computers extensively. Mechanical engineers are routinely responsible for the integration of sensors, controllers, and machinery. Computer technology helps mechanical engineers create and analyze designs, run simulations and test how a machine is likely to work, interact with connected systems, and generate specifications for parts.

The following are examples of types of mechanical engineers:

Auto research engineers seek to improve the performance of cars. These engineers work to improve traditional features of cars such as suspension, and they also work on aerodynamics and new possible fuels.

Heating and cooling systems engineers work to create and maintain environmental systems wherever temperatures and humidity must be kept within certain limits. They develop such systems for airplanes, trains, cars, schools, and even computer rooms.

Robotic engineers plan, build, and maintain robots. These engineers plan how robots will use sensors for detecting things based on light or smell, and they design how these sensors will fit into the designs of the robots.

Role of Mechanical Engineers in Society

- Transportation
- Medical
- Agricultural

- Defense
- Power generation

Transportation

Mechanical engineering is largely concerned with road transportation, and networks, rail and subway systems, airports, and shipping ports.

Medical

A mechanical engineer specialized in medical science can be called as 'medical engineer'. Engineer's responsibilities in medicine can include research, development, testing and evaluation of medical devices, advisement on new biomedical purchases for hospitals and medical centers.

Agricultural

The graduates are trained professionals who understand technology and are capable of solving problems in the areas of agricultural production and management of rural areas with a special focus on machinery.

Defense

Manage the teams of skilled technicians that monitor, maintain and repair formidable military hardware such as tanks, artillery guns and armored logistic vehicles. Not all types of entry are open for this job.

Power generation

When working in thermal power plants, mechanical engineers make sure heavy machinery like boilers and turbines, are working in optimal condition and power is continually generated. Mechanical engineers also work with the operations of the plant.

EMERGING TRENDS AND TECHNOLOGIES IN DIFFERENT SECTOR.

- **Energy sector** - Mechanical engineers in the energy industry design and operate fossil fuel, hydroelectric, conventional, nuclear, and cogeneration power plants. They are involved in all aspects of the production and conversion of energy from one form to another. Mechanical engineers are also involved in exciting projects such as developing alternatives to thermal energy, power cycle devices, fuel cells, gas turbines, and innovative uses of coal, wind, and tidal flow.
- **Manufacturing industry**- A majority of the roles in this sector are focused on supply network logistics/operations or manufacturing/ engineering. The jobs in this sector are not demarcated in different compartments. The jobs here are a mix of different engineering disciplines.

- **Automobile Industry** – This industry is one of the fastest growing and has therefore opened up numerous job opportunities. The role of a mechanical engineer spans the design, manufacturing, and maintenance of motor vehicles. With the advancement in technology when breakthrough ideas like driverless cars, pod-based transportation systems, and bullet trains, are being considered. Top companies and automobile brands are investing a lot in research and recruiting skilled and passionate mechanical engineers.
- **Aerospace industry** – This industry has witnessed a lot of innovations and discoveries. Flying cars, reusable satellites, and rockets are now not unheard of as technology is progressing so is the demand for newer inventions. The requirement for skilled mechanical engineers with knowledge and expertise is growing day by day. Numerous job roles are being offered here ranging from design, to manufacture to testing to R&D. The mechanical engineers get a chance to employ the principles of physics to aeromodelling and dynamics to improve the design and efficiency of systems.
- **Marine industry** – Mechanical engineers in this industry design build operate and maintain equipment and marine vessels. These engineers design, install, or maintain engines, shafts, boilers, and propellers. They could be a part of the team that enforces regulations for air and sea pollution or be a part of designing futuristic cleaner ships.
- **Materials and metals industry** – This job role demands the design, development, and testing of a wide variety of complex mechanical systems. This will include the entire life cycle maintenance of the mechanical items that are used in the plant. A few of those are gas and steam turbines, pipework, valves, fans, coal mills, and so on.

Automotive Industry: The automotive industry includes industries associated with the production, wholesaling, retailing, and maintenance of motor vehicles.

Top 10 Automotive Industry Trends

- Autonomous Vehicles (AVs)
- Vehicle Connectivity.
- Electrification.
- Shared Mobility.
- Artificial Intelligence.
- Big Data & Analytics.
- Human-Machine Interfaces.
- 3D Printing

Several automotive industry trends are impacting its future in 2023 and beyond. These trends involve how vehicles are powered, driven, shopped for, and acquired. Plus, there are statistics you must know about if you plan to buy a vehicle in 2023. Here are the top 10 trends shaping the future of the rapidly changing auto industry and some critical motor vehicle-related statistics.

Trends Shaping The Auto Industry

1. Increased Production Of Electric Cars With Digital Technology
2. More Connected Cars
3. Autonomous Self-Driving Vehicles
4. Truck Platooning
5. Automakers And Technology Company Partnerships

1. Increased Production of Electric Cars With Digital Technology

Automakers continue to integrate more digital technology into their vehicles. Technology companies like Google and Tesla are also working on electric and self-driving vehicles. As a result, it's clear that vehicles produced in 2023 and beyond will be full of technology to address digital touch points. There's fierce competition to develop software and digital and electronic operating systems to power and control the new, innovative zero-emission electric vehicles. These new vehicles will be filled with digital technology.

2. More Connected Cars

Connected cars are vehicles connected to the Internet of Things using wireless means. These vehicles provide a safe, comfortable, convenient multimedia experience by using on-demand features that allow you to do anything you want on the web while in your vehicle. Connected cars can communicate directionally with various other systems outside their local network. The vehicles can share internet access and data with devices inside and outside the car. Connected cars now send digital data and remote diagnostics, vehicle health reports, data-only telematics, access 4G LTE Wi-Fi Hotspots, get turn-by-turn directions, warn of car health issues and directly intervene to prevent breakdowns. Over a billion customer requests were processed by 2015, and connected car technology will explode on the scene in diverse ways in 2023 using predictive intelligence and maintenance technology.

3. The Emergence of Fuel Cell Electric Vehicles

In 2023, the worldwide emergence of fuel-cell electric vehicles is poised. More and more people embrace fuel cell electric vehicles because they recharge faster, have up to 5 times the range of other electric vehicles, and only emit water out of their tailpipes. Many cars, truck, and SUV manufacturers are investing in fuel-cell electric vehicle development.

4. Autonomous Self-Driving Vehicles

Autonomous self-driving vehicles are here and will be more prevalent in 2023 and beyond. Research has shown autonomous vehicles are safer, reduce downtime, expand the last-mile delivery scope, reduce driver fatigue and negligence-related accidents, improve fuel efficiency by 10%, and reduce CO2 emissions by 42 million metric tons annually. Several trucking companies have installed self-driving technology and have tested it at locations nationwide. Beginning in 2023, it will become commonplace to see a fleet of autonomous self-driving commercial trucks or a self-driving Tesla in the lane next to you.

5. Truck Platooning

Another automotive industry trend you will see more in 2023 is truck platooning. This is when multiple trucks use vehicle-to-vehicle connectivity to drive close behind each other while traveling at high speeds.

6. Automakers and Technology Company Partnerships

With the rapid rate at which new technological advancements are being added to cars and other vehicles, it's not surprising to see automakers and technology companies forming partnerships. Electric, connected, and autonomous vehicles require specialized software and advanced technology to function safely and correctly. Car, truck and SUV manufacturers must either make massive investments in their technology divisions or partner with tech companies that can design and produce the new operating systems the next generation of technologically advanced automobiles will need.

ENERGY- Capacity to do work.

“Energy” is a word derived from the Greek word *-Energia*”, meaning the capacity to do work. Energy is defined as the capacity either latent or apparent to do work. Energy exists in various forms such as mechanical energy, electrical energy, thermal energy, and chemical energy. One form of energy can be readily converted into another form, but the total amount of energy remains constant before and after the transformation.

Energy is the basic ingredient of all modern societies. Energy is required to fulfill the basic needs of food, housing, clothing, medical aid education, etc., as well as for travel and communication. More and more production of energy per person enhances the comforts, conveniences, and pleasures of life. Hence energy can be treated as an essence of modern civilization and the per capita consumption of energy is regarded as an index of advancement of a society.

- Most of the energy that we use is mainly derived from conventional energy sources.
- Due to the vast demand of energy, the rate of depletion of these resources has reached alarmingly low levels.
- This situation has directed us to seek alternate energy sources such as solar, wind, ocean, biomass, Hydel etc.

Energy Sources:

- The energy existing in the earth is known as CAPITAL energy.
- Energy that comes from outer space is called CELESTIAL or INCOME energy.
- The CAPITAL energy sources are mainly, fossil fuels, nuclear fuels, and heat traps.
- CELESTIAL ENERGY SOURCES ARE- Electromagnetic, gravitational, and particle energy from stars, planets, moon etc.
- The ELECTROMAGNETIC ENERGY of the earth’s sun is called DIRECT SOLAR ENERGY. This results in WIND, HYDEL, GEOTHERMAL, BIOFUEL, etc.
- GRAVITATIONAL ENERGY of Earth’s moon produces TIDAL ENERGY.

Renewable Sources of Energy:

Energy sources that are continuously produced in nature and are essentially inexhaustible are called renewable energy sources.

1. Direct solar energy
2. Wind energy
3. Tidal energy
4. Hydel energy
5. Ocean thermal energy
6. Bioenergy
7. Geothermal energy
8. Solid wastes
9. Hydrogen
10. Fuel wood
11. Fuel cells
12. Peat

Non Renewable Energy Sources

Energy sources that have been accumulated over the ages and not quickly replenishable when they are exhausted.

1. Fossil fuels.
2. Nuclear fuels.
3. Heat traps.

Different sources of energy:

The sources of energy are classified in the following two ways:

- (a) Conventional and non-conventional sources of energy
- (b) Renewable and non-renewable sources of energy

Conventional energy sources

The sources of energy which provide a net supply of energy are called **conventional sources of energy**. Most of our present energy needs come mainly from the fossil fuels (coal, petroleum etc.) and hydel sources, which are relatively cheaper. These are useful for mass generation of power.

The ever increasing demand in energy is leading to depletion of the fossil fuels. Hydel source cannot be used always since it is not available everywhere and also due to variations in the hydrological cycle. Moreover, the cost of generation is also high due to high initial investments and transmission problems. In view of the above, other sources of energy which are inexhaustible in nature are being sought after.

Non-conventional energy sources

The alternate energy sources that are being harnessed are, solar energy, wind energy, tidal energy, ocean thermal energy, geothermal energy, bio energy, fuel cells, solid wastes, hydrogen energy etc. These inexhaustible sources of energy are called **non-conventional energy sources**.

These sources of energy which provide energy is in dilute form. These are useful for generating power in lesser magnitude.

The renewable sources of energy are defined as the energy sources which are continuously produced in nature and are essentially inexhaustible or non-depletable. These energy sources replenish themselves naturally in a relatively short time and therefore will always be available.

E.g. of renewable energy sources: direct solar energy, wind energy, tidal energy, hydel energy, ocean thermal energy, bio energy, geothermal energy, peat, fuel wood, fuel cells, solid wastes, hydrogen energy etc.

Of the above renewable energy sources, geothermal energy, peat and fuel wood must be used at a rate less than their renewal rate in the nature, to allow them to build up again in nature.

The non-renewable energy sources are defined as the energy sources which have been accumulated over the ages and not quickly replenish able when they are exhausted. E.g. Fossil fuels (coal, petroleum and petroleum products), nuclear fuels and heat traps

Non-renewable sources of energy are those which occur once in nature and on usage they practically cease to form under new geological conditions. They are also called as **exhaustible** or **depletable** sources of energy. Fossil fuels and nuclear fuels are non-renewable sources of energy.

Difference between Conventional and non- conventional sources of energy:

Conventional sources of energy	Non- conventional sources of energy
These are widely used and economical	These are rarely used and initial cost is high
Most of them are exhaustible	Most of them are in-exhaustible
Most of them are pollute the environment	Most of them are environment friendly
They are reliable (continuous supply of energy is possible)	They are not reliable (continuous supply of energy is not possible)
Energy transmission cost is high	Energy transmission cost is low
Example: Fossil fuels, Hydel energy	Example: solar, wind, tidal etc.

Differences between Renewable and Non Renewable Energy Sources

Factor	Renewable Energy Sources	Non Renewable Energy Sources
Exhaustibility/Inexhaustibility	Inexhaustible	Exhaustible
Availability	Abundantly and freely available	Not abundantly available

Replenishment	Replenished Naturally	Cannot be replenished
Environmental Friendliness	Environment friendly except in case of biomass	Not environment friendly
Cost Factor	Building Systems cost is high, running cost is low	Production cost is high
Nature of Availability	Intermittently available	Continuously available
Regional restriction and dependency factor	No regional restriction	Available in certain countries

FOSSIL FUELS:

Fuel is a substance which, when burnt, i.e. on coming in contact and reacting with oxygen or air, produces heat. Thus, the substances classified as fuel must necessarily contain one or several of the combustible elements: carbon, hydrogen, Sulphur, etc. In the process of combustion, the chemical energy of fuel is converted into heat energy.

TYPES OF FUELS

The important fuels are as follows-

1) Solid fuels

2) Liquid fuels

3) Gaseous fuels

Solid fuels are mainly classified into two categories:

- Natural fuels: wood, coal, etc.
- Manufactured fuels: charcoal, coke, briquettes, etc.

Wood:

The most commonly used and easily obtainable solid fuel is wood. It is the oldest type of fuel which man had used for centuries after the discovery of the fire itself. Charcoal is an artificial fuel obtained from wood.

Charcoal:

Charcoal is a produce derived from destructive distillation of wood, being left in the shape of solid residue. Charcoal burns rapidly with a clear flame, producing no smoke and developing heat of about 6050 cal/kg.

Coal:

Coal is a combustible black or brownish-black sedimentary rock usually occurring in rock strata in layers or veins called coal beds or coal seams. The major chemical elements in coal are: carbon, hydrogen and oxygen.

There are two types of coals: i) Bituminous coal ii) Anthracite coal.

1) Solid fuels

- Coal is the major fuel used for thermal power plants to generate steam.
- Coal occurs in nature, which was formed by the decay of vegetable matters buried under the earth millions of years ago under pressure and heat.
- This phenomenon of transformation of vegetable matter into coal under earth's crust is known as Metamorphism.
- The type of coal available under the earth's surface depends upon the period of metamorphism and the type of vegetable matter buried, also the pressure and temperature conditions.
- The major constituents in coal moisture (5-40%), volatile matter (combustible & or incombustible substances about 50%) and ash (20-50%).
- The chemical substances in the coal are carbon, hydrogen, nitrogen, oxygen and Sulphur.
- In the metamorphism phenomenon, the vegetable matters undergo the transformation from peat to anthracite coal, with intermediate forms of lignite and bituminous coal.

Advantages of solid fuels:

- (a) They are easy to transport.
- (b) They are convenient to store without any risk of spontaneous explosion.
- (c) Their cost of production is low.
- (d) They possess moderate ignition temperature.

Disadvantages of solid fuels:

- (a) Their ash content is high.
- (b) Their large proportion of heat is wasted.
- (c) Their combustion operation cannot be controlled easily.
- (d) Their cost of handling is high.

2) Liquid Fuels

Liquid fuels include Gasoline, Diesel oil, Kerosene, Heavy oil, Naptha, Lubricating oils, etc. These are obtained mostly by fractional distillation of crude petroleum or liquefaction of coal.

Gasoline or Petrol:

The straight run gasoline is obtained either from distillation of crude petroleum or by synthesis. It contains some undesirable unsaturated straight chain hydrocarbons and Sulphur compounds. It has boiling range of 40-120°C

Diesel Fuel:

The diesel fuel or gas oil is obtained between 250-320°C during the fractional distillation of crude petroleum. This oil generally contains 85% C. 12% H. Its calorific value is about 11000 kcal/kg.

The suitability of a diesel fuel is determined by its cetane value. Diesel fuels consist of longer hydrocarbons and have low values of ash, sediment, water and sulphate contents.

- All types of liquid fuels used are derived from crude petroleum and its by-products.
- The **petroleum or crude oil** consists of 80-85% C, 10-15% hydrogen, and varying percentages of Sulphur, nitrogen, oxygen and compounds of vanadium.
- The crude oil is refined by fractional distillation process to obtain fuel oils, for industrial as well as for domestic purposes.
- The fractions from light oil to heavy oil are naphtha, gasoline, kerosene, diesel and finally heavy fuel oil.
- The heavy fuel oil is used for generation of steam.
- The use of liquid fuels in thermal power plants has many advantages over the use of solid fuels.

Some important advantages are as follows:

1. The storage and handling of liquid fuels is much easier than solid and gaseous fuels.
2. Excess air required for the complete combustion of liquid fuels is less, as compared to the solid fuels.
3. Fire control is easy and hence changes in load can be met easily and quickly.
4. There are no requirements of ash handling and disposal.
5. The system is very clean, and hence the labour required is relatively less compared to the operation with solid fuels.

Disadvantages of liquid fuels:

- a. The cost of liquid fuel is relatively much higher as compared to solid fuel.
- b. Costly special storage tanks are required for storing liquid fuels.
- c. There is a greater risk of fire hazards, particularly, in case of highly inflammable and volatile liquid fuels.
- d. For efficient burning of liquid fuels, specially constructed burners and spraying apparatus are required.

3) Gaseous Fuels

Gaseous fuels occur in nature, besides being manufactured from solid and liquid fuels.

Natural Gas:

Natural gas is generally associated with petroleum deposits and is obtained from wells dug in the oil-bearing regions. The approximate composition of natural gas is:
 $\text{CH}_4 = 70.9\%$, $\text{C}_2\text{H}_6 = 5.10\%$, $\text{H}_2 = 3\%$, $\text{CO} + \text{CO}_2 = 22\%$.

Producer Gas:

Producer gas is essentially a mixture of combustible gases carbon monoxide and hydrogen associated with non-combustible gases N_2 , CO_2 , etc. It is prepared by passing air mixed with little steam (about 0.35 kg/kg of coal) over a red hot coal or coke bed maintained at about 1100°C in a special reactor called gas producer. It consists of a steel vessel about 3 m in diameter and 4 m in height. The vessel is lined inside with fire bricks. It is provided with a cup and cone feeder at the top and a side opening for the exit of producer gas. At the base, it has an inlet for passing air and steam. The producer at the base is also provided with an exit for the ash formed.

- For the generation of steam in gas-fired thermal plants, either natural gas or manufactured gaseous fuels are used.
- However, manufactured gases are costlier than the natural gas.
- Generally, natural gas is used for power plants as it is available in abundance.
- The natural gas is generally obtained from gas wells and petroleum wells.
- The major constituent in natural gas is methane, about 60-65%, and also contains small amounts of other hydrocarbons such as ethane, naphthene and aromatics, carbon dioxide, and nitrogen.
- The natural gas is colorless, odorless and non-toxic.

- The natural gas is transported from the source to the place of use through pipes, for distances to several hundred kilometers.
- Its calorific value ranges from 25,000 to 50,000 kJ/m³, in accordance with the percentage of methane in the gas.
- The artificial gases are producer gas, water gas coke-oven gas; and the Blast furnace gas.
- Generally, power plants fired with artificial gases are not found.
- The gaseous fuels have advantages similar to those of liquid fuels, except for the storage problems.
- The major disadvantage of power plant using natural gas is that it should be setup near the source; otherwise the transportation losses are too high.

Advantages of gaseous fuels:

- a. They can be conveyed easily through pipelines to the actual place of need, thereby eliminating manual labour in transportation.
- b. They can be lighted at ease.
- c. They have high heat contents and hence help us in having higher temperatures.
- d. They can be pre-heated by the heat of hot waste gases, thereby affecting economy in heat.
- e. Their combustion can readily be controlled for change in demand like oxidizing or reducing atmosphere, length flame, temperature, etc.
- f. They do not require any special burner.
- g. They are free from impurities found in solid and liquid fuels.

Disadvantages gaseous fuels:

- a. Very large storage tanks are needed.
- b. They are highly inflammable, so chances of fire hazards in their use is high.

HYDEL POWER PLANT

Hydroelectric power (often called hydropower) is considered a renewable energy source. A renewable energy source is not depleted (used up) in the production of energy. Through hydropower, the energy in falling water is converted into electricity without using up the water. In hydroelectric power plants, the potential energy of water due to its high location is converted into electrical energy.

The total power generation capacity of the hydroelectric power plants depends on the head of water and the volume of water flowing towards the water turbine. The hydroelectric power plant, also called a dam or hydropower plant, is used for the generation of electricity from water on a large-scale basis.

The dam is built across the large river that has sufficient quantity of water throughout the river. In certain cases, where the river is very large, more than one dam can build across the river at different locations.

An impoundment is simply a dam that holds water in a reservoir. The water is released when needed through a penstock, to drive the turbine (remember turbines are just advanced waterwheels). The flowing water causes the turbine to rotate, converting the water 's kinetic energy into mechanical energy. The mechanical energy produced by the turbine is converted into electric energy using a turbine generator.

Working Principle of Hydroelectric Power plant

The water flowing in the river possesses two type of energy:

- (1) The kinetic energy due to flow of water and
- (2) Potential energy due to the height of water.

The hydroelectric power and potential energy of water is utilized to generate electricity.

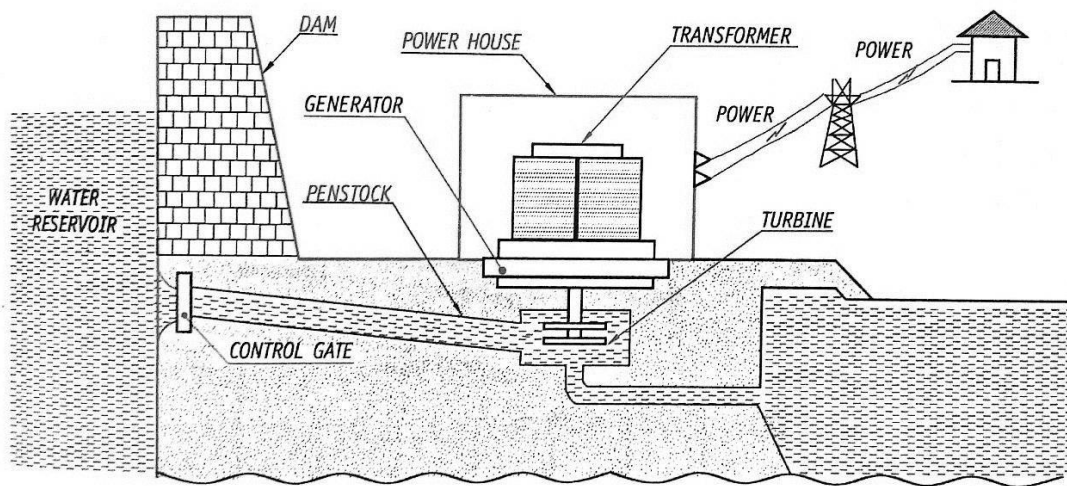

Hydro-Power Station

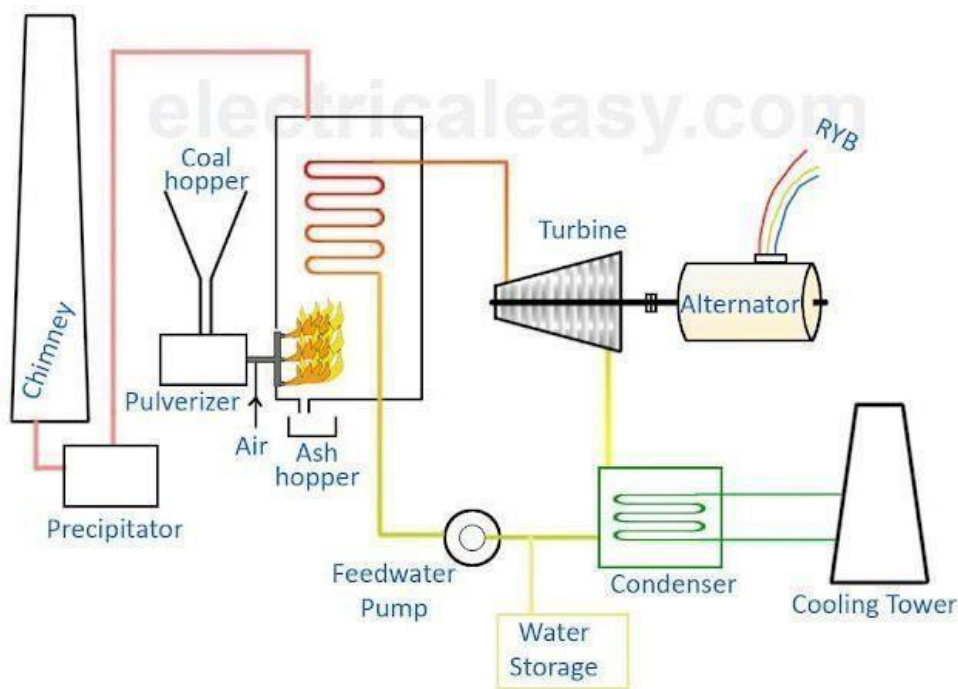
THERMAL POWER PLANT

Almost two third of electricity requirement of the world is fulfilled by **thermal power plants** (or **thermal power stations**). In these power stations, steam is produced by burning some fossil fuel (e.g. coal) and then used to run a steam turbine. Thus, a thermal power station may sometimes have called as a **Steam Power Station**. After the steam passes through the steam turbine, it is condensed in a condenser and again fed back into the boiler to become steam. This is known as **ranking cycle**. This article explains **how electricity is generated in thermal power plants**. As majority of thermal power plants use coal as their primary fuel, this article is focused on a **coal-fired thermal power plant**.

Coal: In a coal-based thermal power plant, coal is transported from coal mines to the generating station. Generally, bituminous coal or brown coal is used as fuel. The coal is stored in either 'dead storage' or in 'live storage'. Dead storage is generally 40 days' backup coal storage which is used when coal supply is unavailable. Live storage is a raw coal bunker in a boiler house. The coal is cleaned in a magnetic cleaner to filter out if any iron particles are present which may cause wear and tear in the equipment. The coal from live storage is first crushed in small particles and then taken into pulverized to make it in powdered form. Fine powdered coal undergoes complete combustion, and thus pulverized coal improves the efficiency of the boiler. The ash produced after the combustion of coal is taken out of the boiler furnace and then properly disposed of. Periodic removal of ash from the boiler furnace is necessary for the proper combustion.

Boiler: The mixture of pulverized coal and air (usually preheated air) is taken into the boiler and then burnt in the combustion zone. On ignition of fuel, a large fireball is formed at the center of the boiler and a large amount of heat energy is radiated from it. The heat energy is utilized to convert the water into steam at high temperature and pressure. Steel tubes run along the boiler walls in which water is converted into steam. The flue gases from the boiler make their way through the super heater, economizer, and air preheater and finally get exhausted to the atmosphere from the chimney.

- **super heater:** The super heater tubes are hung at the hottest part of the boiler. The saturated steam produced in the boiler tubes is superheated to about 540 °C in the super heater. The superheated high-pressure steam is then fed to the steam turbine.
- **Economizer:** An economizer is essentially a feed water heater that heats the water before supplying it to the boiler.
- **Air pre-heater:** The primary air fan takes air from the atmosphere and it is then warmed in the air pre-heater. Pre-heated air is injected with coal in the boiler. The advantage of pre-heating the air is that it improves the coal combustion.

Steam turbine: High pressure super-heated steam is fed to the steam turbine which causes turbine blades to rotate. Energy in the steam is converted into mechanical energy in the steam turbine which acts as the prime mover. The pressure and temperature of the steam falls to a lower value and it expands in volume as it passes through the turbine. The expanded low pressure steam is exhausted in the condenser.

Condenser: The exhausted steam is condensed in the condenser by means of cold water circulation. Here, the steam loses its pressure as well as temperature and it is converted back into water. Condensing is essential because, compressing a fluid which is in gaseous state requires a huge amount of energy with respect to the energy required in compressing liquid. Thus, condensing increases efficiency of the cycle.

Alternator: The steam turbine is coupled to an alternator. When the turbine rotates the alternator, electrical energy is generated. This generated electrical voltage is then stepped up with the help of a transformer and then transmitted where it is to be utilized.

Feed water pump: The condensed water is again fed to the boiler by a feed water pump. Some water may be lost during the cycle, which is suitably supplied from an external water source.

This was the **basic working principle of a thermal power station** and its typical components. A practical thermal plant possesses a more complicated design and multiple stages of turbine such as High-Pressure Turbine (HPT), Intermediate Pressure Turbine (IPT), and Low-Pressure Turbine (LPT).

Advantages:

- Less initial cost as compared to other generating stations.
- It requires less land as compared to hydro power plant.
- The fuel (i.e. coal) is cheaper.
- The cost of generation is lesser than that of diesel power plants.

Disadvantages:

- It pollutes the atmosphere due to the production of large amount of smoke. This is one of the causes of global warming.
- The overall efficiency of a thermal power station is low (less than 30%).

NUCLEAR POWER PLANT

Nuclear energy is the energy released during nuclear fission or fusion, especially when used to generate electricity. Nuclear fuel is any material that can be consumed to derive nuclear energy. The most common type of nuclear fuel is fissile elements that can be made to undergo nuclear fission chain reactions in a nuclear reactor. The most common nuclear fuels are ^{235}U and ^{239}Pu .

The basic nuclear generating station energy cycle is shown in Figure. Fuel containing fissile material (Uranium) is fed to the reactor where fission takes place. The energy liberated appears in the form of heat, which is used to boil water in Heat exchanger or steam generator.

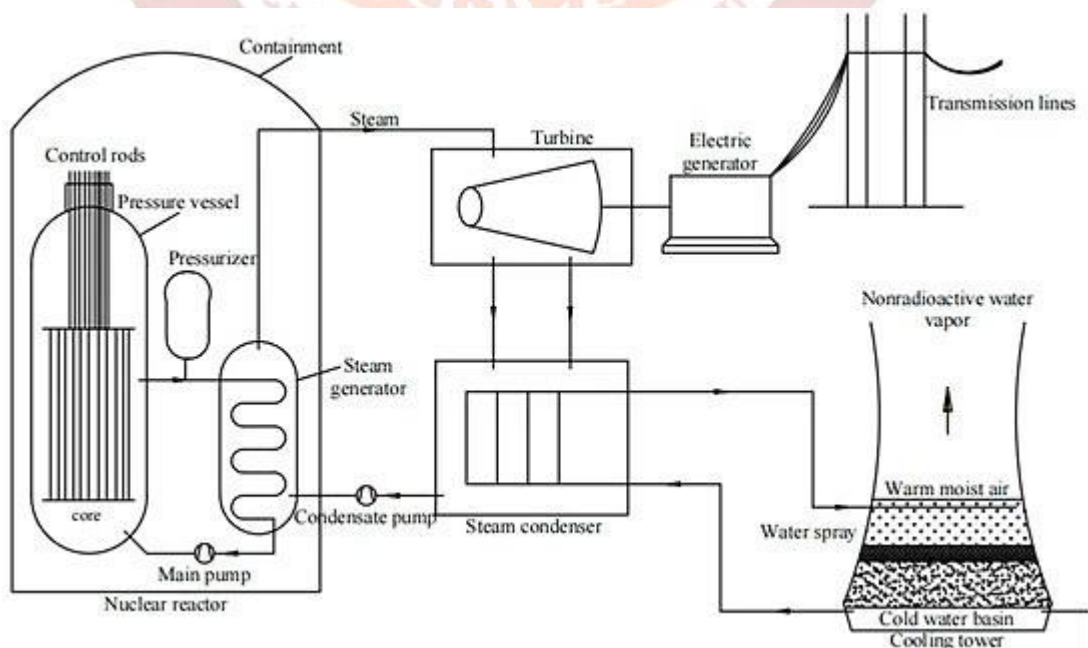

The steam produced from the boiling water spins a turbine-generator set, where the heat is converted first to kinetic energy and then it will convert to mechanical energy in the turbine and to electricity by the generator.

Working principle of a nuclear power station

The schematic diagram of nuclear power station is shown in figure. A generating station in which nuclear energy is converted into electrical energy is known as nuclear power station. The main components of this station are nuclear reactor, heat exchanger or steam generator, steam or gas turbine, AC generator and exciter, and condenser. The reactor of a nuclear power plant is similar to the furnace in a steam power plant. The heat liberated in the reactor due to the nuclear fission of the fuel is taken up by the coolant circulating in the reactor. A hot coolant leaves the reactor at top and then flows through the tubes of heat exchanger and transfers its heat to the feed water on its way. The steam produced in the heat exchanger is passed through the turbine and after the work has done by the expansion of steam in the turbine, steam leaves the turbine and flows to the condenser. The mechanical or rotating energy developed by the turbine is transferred to the generator which in turn generates the electrical energy and supplies to the bus through a step-up transformer, a circuit breaker, and an isolator. Pumps are provided to maintain the flow of coolant, condensate, and feed water.

SOLAR ENERGY

Solar radiation is radiant energy emitted by the sun from a nuclear fusion reaction that creates electromagnetic energy. The spectrum of **solar radiation** is close to that of a black body with a temperature of about 5800 K. About half of the **radiation** is in the visible short-wave part of the electromagnetic spectrum.

Solar Constant:

This is the amount of energy received in unit time on a unit perpendicular to the sun's direction at the mean distance of the earth from the sun. The surface of the earth receives about 10^{14} kW of solar energy from the sun. One square meter of the land exposed to direct sun-light receives an energy equivalent of about 1 kW of power. The radiant solar energy falling on the earth surface is directly converted into thermal energy. The surfaces on which the solar rays fall are called collectors.

There are two types of collectors:

- (a) Flat plate collectors
- (b) Focusing collectors.

Liquid Flat Plate Collectors:

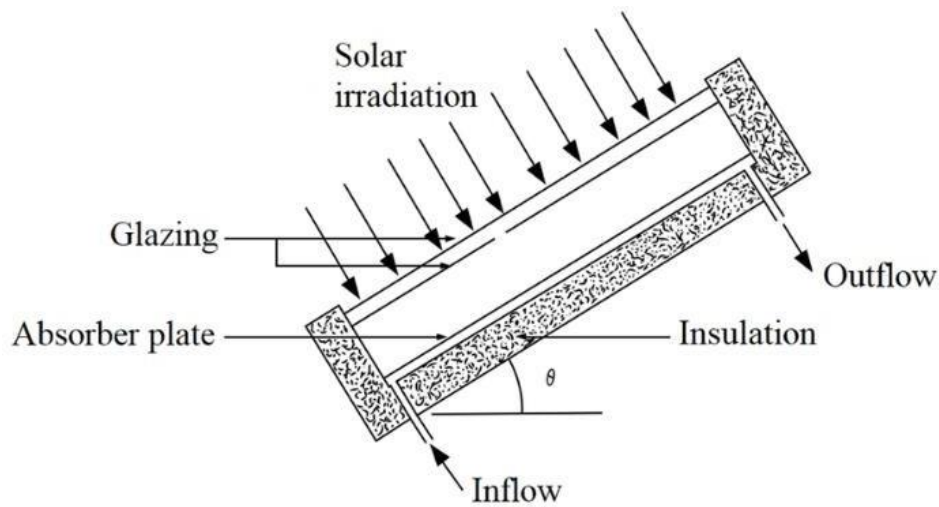

It has the following components:

(a) Absorbing plate

- Made of Copper, Aluminium or steel.
- It is coated with material to enhance the absorption of solar radiation.
- From the absorbing plates heat is transferred to tubes which carry either water or air.

(b) Transparent covers

- Sheets of solar radiation transmitting materials placed above the absorbing plate.
- They allow solar energy to reach the absorbing plate while reducing convection, conduction and re-radiation heat losses.

(c) Insulation

- It minimizes and protects the absorbing plate from heat losses.

Working

- Sun's rays falling on the transparent covers are transmitted to the absorbing plate.
- The absorbing plate usually of Cu, Al or galvanized iron is painted dead black for maximum absorption.
- The collector (plate) will absorb the sun energy and transfer it to the fluid in the pipe beneath the collector plate.
- Use of flat mirrors on the sides improves the output.

Solar Pond Technology:

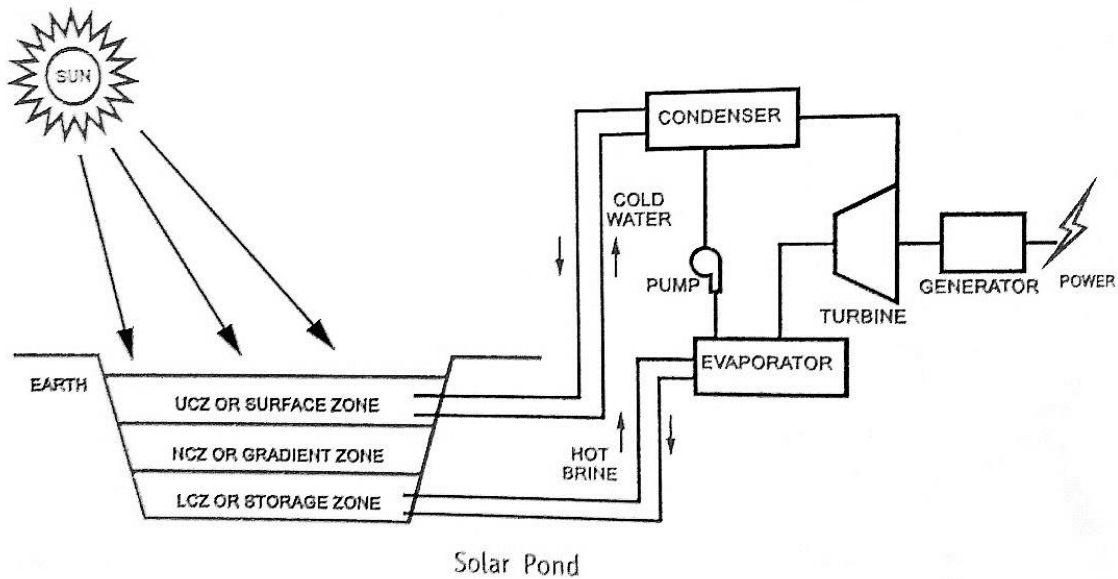

- A salinity gradient solar pond is an integral collection and storage device of solar energy.
- By virtue of having built-in thermal energy storage, it can be used irrespective of time and season.
- In an ordinary pond or lake, when the sun's rays heat up the water this heated water, being lighter, rises to the surface and loses its heat to the atmosphere.
- The net result is that the pond water remains at nearly atmospheric temperature.
- The solar pond technology inhibits this phenomenon by dissolving salt into the bottom layer of this pond, making it too heavy to rise to the surface, even when hot.
- The salt concentration increases with depth, thereby forming a salinity gradient.
- The sunlight which reaches the bottom of the pond remains entrapped there.
- The useful thermal energy is then withdrawn from the solar pond in the form of hot brine.
- The pre-requisites for establishing solar ponds are: a large tract of land (it could be barren), a lot of sun shine, and cheaply available salt (such as Sodium Chloride) or bittern.
- Generally, there are three main layers. The top layer is cold and has relatively little salt content.
- The bottom layer is hot -- up to 100°C (212°F) -- and is very salty.
- Separating these two layers is the important gradient zone.

Photovoltaic Cell:

Solar energy can be directly converted to electrical energy using the photovoltaic effect. Photovoltaic effect is defined as the generation of an electromotive force (EMF) as a result of the absorption of ionizing radiation.

Devices that convert sunlight to electricity are known as solar cells or photovoltaic cells. Solar cells are semiconductors, commonly used are barrier-type iron-selenium cells.

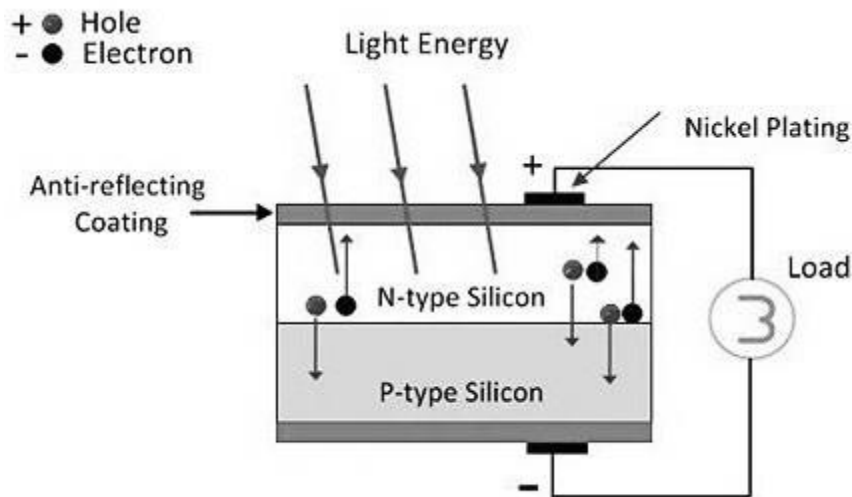

Conversion of solar energy into electrical energy can be achieved by the photovoltaic effect caused by the solar radiations. Photo-voltaic effect can be observed in variety of materials but best performance is given by semiconductors (like silicon).

Since silicon is a tetravalent material has four valence electrons. After doping with pentavalent material (like arsenic, phosphorous) it forms N-type semiconductor and the same with trivalent material (like boron) it forms P-type semiconductor. When P-N junction of semiconductor is exposed to sunlight, a voltage around 0.5 volts is built up around the junction and current depends on the exposed area of cell. By applying external load, current is made to flow through the conductor, it will continue as long as the free electrons and holes are formed due to solar radiation.

WORKING OF SOLAR POWER PLANT

As sunlight falls over a solar cell, a large number of photons strike the p-type region of silicon. Electron and hole pair will get separated after absorbing the energy of a photon. The electron travels from p-type region to n-type region due to the action of electric field at p-n junction. Further the diode is reversed biased to increase this electric field. So this current starts flowing in the circuit for individual solar cell. We combine the current of all the solar cells of a solar panel, to get a significant output.

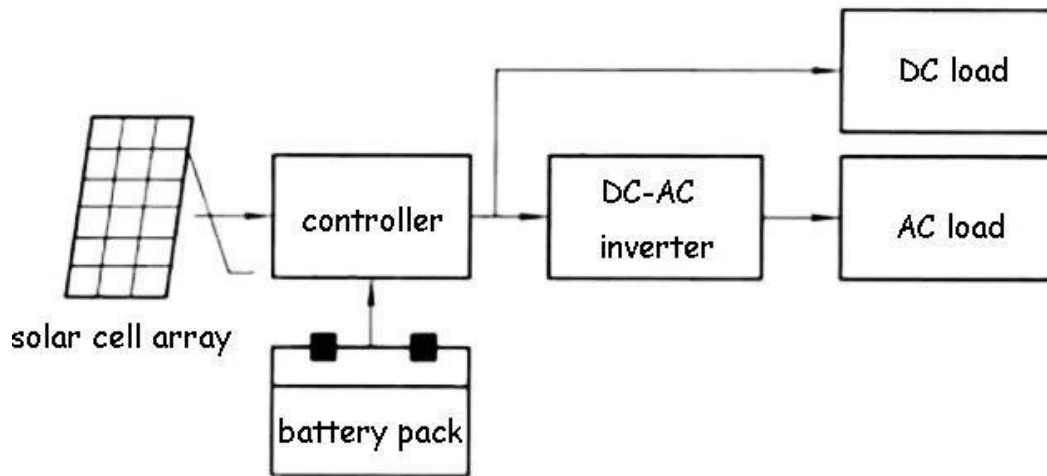

Schematic diagram of solar power generation system

Solar power plant has a large number of solar panels connected to each other to get a large voltage output. The electrical energy coming from the combined effort of solar panels is stored in the Lithium ion batteries to be supplied at night time, when there is no sunlight.

Energy Storage

Storage of the energy generated by the solar panels is an important issue. Sometimes the unused energy generated during daytime is used to pump water to some height, so that it could be used to generate electricity using its potential energy when required or mainly at night time.

Advantages of Solar Energy

- Most clean and renewable source of energy.
- It is available in abundance and endless.
- It provides electricity at low cost, as fuel is free.
- With new research in this sector we now have a good power storage solution.
- Keeping in mind the pollution and cost of fossil fuel, it's becoming the most reliable source of clean energy.

Disadvantages of Solar Power Plant

- It requires a lot of land to be captured forever.

- The initial cost of installation is too high.
- The energy storage options are not efficient and costly if efficient.
- Power production is quite low as compared to nuclear or other resources to produce power.
- There is a problem if it is cloudy for a few days.
- Their production causes pollution.

Applications

- Solar power plants are powering cities most efficiently.
- Solar panels could be used to generate electricity individually for each house, especially in remote areas.

WIND ENERGY

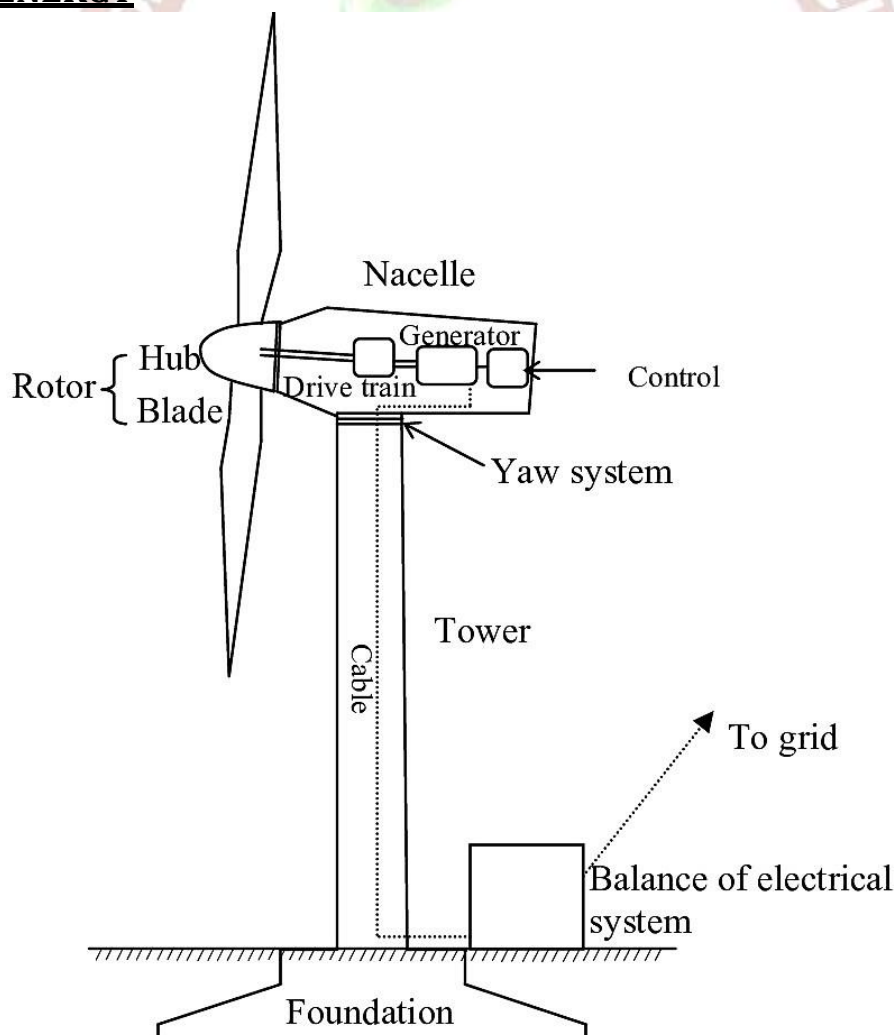

Winds arise primarily from temperature difference of the earth 's surface resulting from unequal exposure to (or absorption of) solar radiation. Wind possesses kinetic energy. The kinetic energy of wind can be converted into mechanical energy that can be utilized to perform useful work or to generate electricity. Wind energy conversion devices are commonly known as **wind turbines**. The wind turbine consists of a number of vanes or blades radiating from a hub or central axis. When the wind blows against the vanes of a wind turbine, rotational motion is caused in the wind turbine. Thus, the kinetic energy of wind is converted into mechanical work. This mechanical work can be used directly to run a machine or to run a generator to produce electricity. Wind energy can be utilized in places wind velocity is considerably high. An ideal wind speed that can be utilized to extract energy lies between a speed 10 km/hr. to 50 km/hr.

The utilization of wind energy for electric power generation is illustrated in figure. The set up consists of a wind turbine keyed to the turbine shaft. The rotational motion of the wind turbine caused due to wind blow is transmitted to the generator through a gear box. A step up transmission is usually required to match the relatively slow speed of the turbine to the higher speed of an electric generator. The combination of wind turbine and generator is usually referred to as an **aero generator**. The electrical energy so generated is obtained through the leads. The set up (usually called tower) consists of wind speed and direction indicator, with the aid of which the tower can be turned to the direction of wind blow.

A windmill is the oldest device built to convert wind energy into mechanical energy used for grinding, milling, and pumping applications. It consists of a rotor fitted with large-sized blades. Now performance improvement is achieved by applying sound engineering and aerodynamic principles. Nowadays wind energy is used to produce electrical energy. Wind energy is converted into mechanical energy in wind turbines. These wind turbines are coupled to generators the mechanical energy is converted into electrical energy.

BIO-FUELS

Biofuels are energy sources made from living things, or the waste that living things produce. Supporters of biofuels argue that their use could significantly reduce greenhouse gas emissions; while burning the fuels produces carbon dioxide, growing plants or biomass removes carbon dioxide from the atmosphere.

Biofuels are liquid fuels that are derived from biomass or bio-waste. Biofuels are produced from sugar crops, starch crops, oilseed crops, and animal fats.

The most common first-generation biofuels are:

- **Bio-oil:** thermo-chemical conversion of biomass. A process still in the development phase.

- **Biochemical:** modification of the bio-ethanol fermentation process including a pretreatment procedure.
- **Thermo chemical:** modification of the bio-oil process to produce syngas and methanol, Fisher-Tropsch diesel or dimethyl ether (DME).

Ethanol:

Ethanol can be produced by the action of microorganisms and enzymes through the fermentation of sugar cane. Ethanol can be used in petrol engines as a replacement for gasoline; it can be mixed with gasoline to any percentage. Most existing car petrol engines can run on blends of up to 15% bioethanol with petroleum/gasoline. Ethanol has a smaller energy density than that of gasoline; this means it takes more fuel (volume and mass) to produce the same amount of work. An advantage of ethanol ($\text{CH}_3\text{CH}_2\text{OH}$) is that it has a higher octane rating than ethanol-free gasoline available at roadside gas stations, which allows an increase of an engine's compression ratio for increased thermal efficiency. In high-altitude (thin air) locations, some states mandate a mix of gasoline and ethanol as a winter oxidizer to reduce atmospheric pollution emissions.

Advantages:

- Unlike petroleum, ethanol is a renewable resource
- Ethanol burns more cleanly in air than petroleum, producing less carbon (soot) and carbon monoxide
- The use of ethanol as opposed to petroleum could reduce carbon dioxide emissions, provided that a renewable energy resource was used to produce crops required to obtain ethanol and to distill fermented ethanol.

Disadvantages:

- Ethanol has a lower heat of combustion (per mole, per unit of volume, and unit of mass) than petroleum
- Large amounts of arable land are required to produce the crops required to obtain ethanol, leading to problems such as soil erosion, deforestation, fertilizer run-off, and salinity.
- Major environmental problems would arise out of the disposal of waste fermentation liquors.
- Typical current engines would require modification to use high concentrations of ethanol.

Biodiesel:

It is produced from oils or fats using transesterification and is a liquid similar in composition to fossil/mineral diesel. Chemically, it consists mostly of fatty acid methyl (or ethyl) esters.

Feedstock for biodiesel includes animal fats, vegetable oils, soy, rapeseed, jatropha, mahua, mustard, flax, sunflower, palm oil, hemp, field pennycress, Pongamia pinnata, and algae. Pure biodiesel (B100) currently reduces emissions by up to 60% compared to diesel

Advantages of biodiesel fuel:

- An excessive production of soybeans in the world makes it an economic way to utilize this surplus for manufacturing the Biodiesel fuel.
- One of the main biodiesel fuel advantages is that it is less polluting than petroleum diesel.
- The lack of sulfur in 100% biodiesel extends the life of catalytic converters.
- Another advantage of biodiesel fuel is that it can also be blended with other energy resources and oil.
- It can also be distributed through existing diesel fuel pumps, which is another biodiesel fuel advantage over other alternative fuels.
- The lubricating property of the biodiesel may increase the lifetime of engines.

Disadvantages of biodiesel fuel:

- At present, Biodiesel fuel is about one and a half times more expensive than petroleum diesel fuel.
- It requires energy to produce biodiesel fuel from soy crops; there is the energy of sowing, fertilizing and harvesting.
- As Biodiesel cleans the dirt from the engine, this dirt can then get collected in the fuel filter, thus clogging it. So, filters have to be changed after the first several hours of biodiesel use.
- Biodiesel fuel distribution infrastructure needs improvement, which is another of the biodiesel fuel disadvantages.

Applications:

- Biogas is a cheap and sustainable fuel used in lighting, cooking, or generating electricity.
- Biodiesel finds its use in the automotive industry mainly in cars and trucks.
- Small engines are seen in lawn movers and chain saws.
- The marine industry finds application of biofuel in suitable blend mixtures to be used in boats and ships.

Problems Associated

Biodiesel is compatible with current engines but with certain issues

The most important of these are:

- Biodiesel exhibits cold weather problems
- Some types of biodiesel have exhibited storage instability that could lead to engine problems
- Diesel additives may not provide the same benefits when used with biodiesel.
- Sometimes, vegetable oils create adverse effects on engine components due to their volatility, molecular structure, and high viscosity.

Comparison of Bio Fuels with Petroleum

Factor	Bio Fuels	Petroleum
Calorific Value	Ranges from 30 to 38MJ/Kg	Varies between 43 to 48MJ/Kg
Emissions	Greenhouse gas emissions are less	Greenhouse gas emissions are more
Biodegradability	Biodegradable	Non- Biodegradable
Toxicity	Non-Toxic	Toxic
Renewability	Renewable	Non-Renewable
Safety	Safe to produce	Not safe to produce

GLOBAL WARMING:

Global warming is a gradual increase in the overall temperature of the earth's atmosphere generally attributed to the greenhouse effect caused by increased levels of carbon dioxide, CFCs, and other pollutants.

Causes for Global Warming:

One of the biggest issues facing us right now is global warming. Its effects on animals and on agriculture are indeed frightening, and the effects on the human population are even scarier. The facts about global warming are often debated in politics and the media, but, unfortunately, even if we disagree about the causes, global warming effects are real, global, and measurable. The causes are mainly from us, the human race, and the effects on us will be severe.

- **Carbon dioxide emissions from fossil fuel-burning power plants**

Our ever-increasing addiction to electricity from coal-burning power plants releases enormous amounts of carbon dioxide into the atmosphere.

- **Carbon dioxide emissions from burning gasoline for transportation**

With our population growing at an alarming rate, the demand for more cars and consumer goods means that we are increasing the use of fossil fuels for transportation and manufacturing.

- **Methane emissions from animals, agriculture such as rice paddies, and from Arctic sea beds**

Methane is another extremely potent greenhouse gas, ranking right behind CO₂. When organic matter is broken down by bacteria under oxygen-starved conditions (anaerobic decomposition) as in rice paddies, methane is produced. The process also takes place in the intestines of herbivorous animals, and with the increase in the amount of concentrated livestock production, the levels of methane released into the atmosphere is increasing. Another source of methane is methane clathrate, a compound containing large amounts of methane trapped in the crystal structure of ice. As methane escapes from the Arctic seabed, the rate of global warming will increase significantly.

- **Deforestation, especially tropical forests for wood, pulp, and farmland**

The use of forests for fuel (both wood and for charcoal) is one cause of deforestation, but in the first world, our appetite for wood and paper products, our consumption of livestock grazed on former forest land, and the use of tropical forest lands for commodities like palm oil plantations contributes to the mass deforestation of our world. Forests remove and store carbon dioxide from the atmosphere, and this deforestation releases large amounts of carbon, as well as reducing the amount of carbon capture on the planet.

- **Increase in usage of chemical fertilizers on croplands**

In the last half of the 20th century, the use of chemical fertilizers (as opposed to the historical use of animal manure) has risen dramatically. The high rate of application of nitrogen-rich fertilizers has effects on the heat storage of cropland (nitrogen oxides have 300 times more heat-trapping capacity per unit of volume than carbon dioxide) and the run-off of excess fertilizers creates 'dead-zones' in our oceans. In addition to these effects, high nitrate levels in groundwater due to over-fertilization are cause for concern for human health.

Effects for Global Warming:

- **Higher temperatures:** Every continent has warmed substantially since the 1950s. There are more hot days and fewer cold days, on average, and the hot days are hotter.
- **Heavier storms:** The world's atmosphere can hold more moisture as it warms. As a result, the overall number of heavier storms has likely increased since midcentury, particularly in North America and Europe (though there's plenty of regional variation).

- **Heat waves:** Heat waves have likely become longer and more frequent around the world over the past 50 years, particularly in Europe, Asia, and Australia.
- **Shrinking sea ice:** The extent of sea ice in the Arctic has shrunk since 1979, by between 3.5 percent and 4.1 percent per decade, on average. Summer sea ice has dwindled even more rapidly:
- **Shrinking glaciers:** Glaciers around the world have, on average, been losing ice since the 1970s. In some areas, that is reducing the amount of available freshwater.
- **Sea-level rise:** Global sea levels rose 25 centimeters (9.8 inches) in the 19th and 20th centuries, after 2,000 years of relatively little change. The pace of sea-level rise has continued to increase in recent decades. Sea-level rise is caused by both the thermal expansion of the oceans — as water warms up, it expands — and the melting of glaciers and ice sheets.
- **Food supply:** A hotter climate can be both good for crops (it lengthens the growing season, and more carbon dioxide can increase photosynthesis) and bad for crops (excess heat can damage plants). The IPCC found that global warming was currently benefiting crops in some high-latitude areas, but that negative effects were becoming increasingly common worldwide.
- **Shifting species:** Many land and marine species have had to shift their geographic ranges in response to warmer temperatures. So far, only a few extinctions have been linked to global warming, such as certain frog species in Central America.

Greenhouse Effect:

The greenhouse effect is the process by which radiation from a planet's atmosphere warms the planet's surface to a temperature above what it would be without its atmosphere. If a planet's atmosphere contains radioactively active gases (i.e., greenhouse gases) they will radiate energy in all directions. Part of this radiation is directed towards the surface, warming it. The intensity of the downward radiation – that is, the strength of the greenhouse effect – will depend on the atmosphere's temperature and on the amount of greenhouse gases that the atmosphere contains.

Earth's natural greenhouse effect is critical to supporting life. Human activities, mainly the burning of fossil fuels and clearing of forests, have strengthened the greenhouse effect and caused global warming.

Ozone Layer:

A layer in the earth's stratosphere at an altitude of about 10 km (6.2 miles) containing a high concentration of ozone, which absorbs most of the ultraviolet radiation reaching the earth from the sun.

Causes for Ozone Layer Depletion:

The decrease in ozone concentration in the middle layers of the atmosphere – mainly in the stratosphere – is extremely damaging to life on earth, and is largely caused by emissions of halogenated hydrocarbons produced by man, CFCs, HCFCs, halons, carbon tetrachloride and methyl bromide. For this reason, such substances are commonly referred to as Substances that Deplete the Ozone Layer (ODS).

- **Chlorofluorocarbons (CFCs)**

They are compounds formed by chlorine, fluorine and carbon. They are often used as refrigerants, solvents, and for the manufacture of spongy plastics. When the chemicals reached the earth's stratosphere, they reacted with Ultraviolet radiation, which caused them to break down and release Chlorine and Bromine into the earth's ozone layer.

- **Hydro chlorofluorocarbons (HCFCs)**

Compounds formed by H, Cl, F and C. They are being used as substitutes for CFCs because many of their properties are similar and are less harmful to ozone by having a shorter half-life and releasing fewer Cl atoms.

- **Halons**

They are compounds formed by Br, F and C. Because of their ability to put out fires are used in fire extinguishers, although their manufacture and use is prohibited in many countries because of their ozone-depleting action. Their ability to harm the ozone layer is very high because they contain Br which is a much more effective atom-destroying ozone than the Cl.

- **Methyl bromide (CH₃Br)**

It is a very effective pesticide that is used to fumigate soils and in many crops.

- **Carbon tetra-chloride (CCl₄)**

It is a compound that has been widely used as a raw material in many industries, for example, to manufacture CFCs and as a solvent.

Effects of Ozone Layer Depletion:

Skin Cancer

Today, it is estimated that skin cancer rates increased due to the decrease in stratospheric ozone (ozone layer). The most common type of skin cancer, called non-melanoma, is the cause of exposures to UV-B radiation for several years.

Effects on aquatic ecosystems

The loss of phytoplankton, the basis of the marine food chain, has been observed as the cause of the increase in ultraviolet radiation.

Effects on terrestrial ecosystems

Animals
For some species, an increase in UV-B radiation implies the formation of skin cancer. This has been studied in goats, cows, cats, dogs, sheep and laboratory animals and is probably pointing out that this is a common feature of several species. Infections in cattle can be aggravated by an increase in UV-B radiation.

Plants

In many plants UV-B radiation can have the following adverse effects: alter its shape and damage plant growth; Reduce tree growth; Change flowering times; Make plants more vulnerable to disease and produce toxic substances. There could even be losses of biodiversity and species.

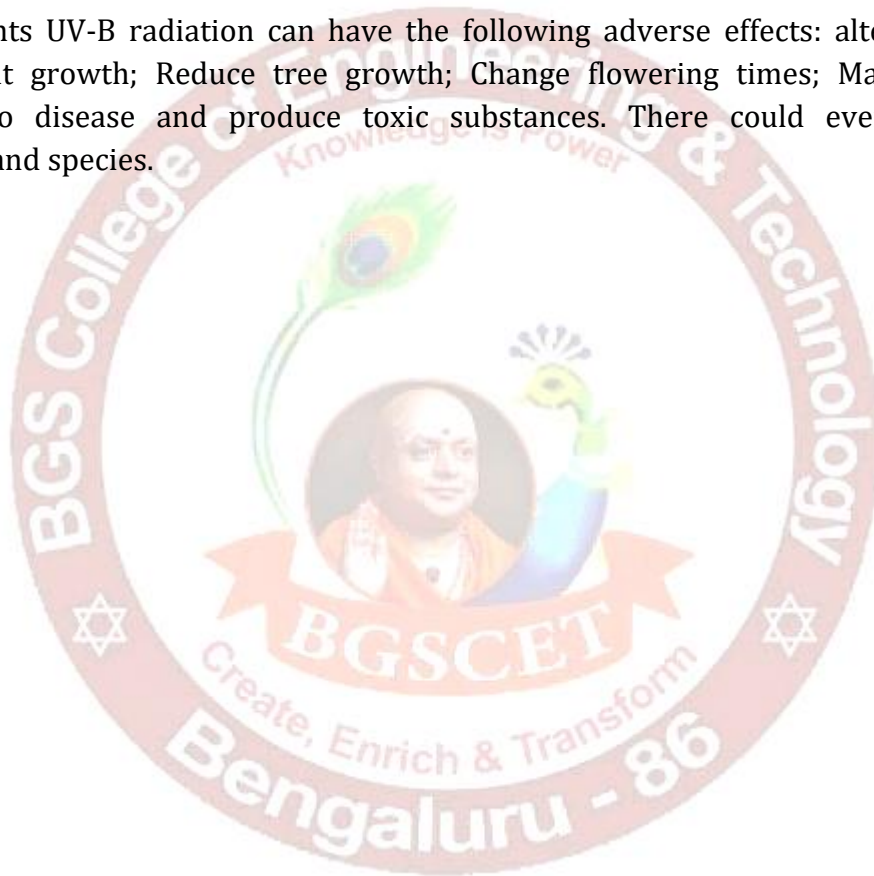

BGS COLLEGE OF ENGINEERING AND TECHNOLOGY

DEPARTMENT OF MECHANICAL ENGINEERING

Mahalakshmi layout, Bengaluru- 560086



INTRODUCTION TO MECHANICAL ENGINEERING (BESCK104D/204D)

MODULE - 02

Syllabus: Module – 2

Machine Tool Operations: Working Principle of lathe, Lathe operations: Turning, facing, knurling. Working principle of Drilling Machine, drilling operations: drilling, boring, reaming. Working of Milling Machine, Milling operations: plane milling and slot milling. (No sketches of machine tools, sketches to be used only for explaining the operations).

Introduction to Advanced Manufacturing Systems: Introduction, components of CNC, advantages and applications of CNC, 3D printing.

Introduction:

Manufacturing process may be defined as a process of converting, the raw material into your finished product of required size and shape depending upon the various processes and methods.

Manufacturing process is broadly classified into two groups.

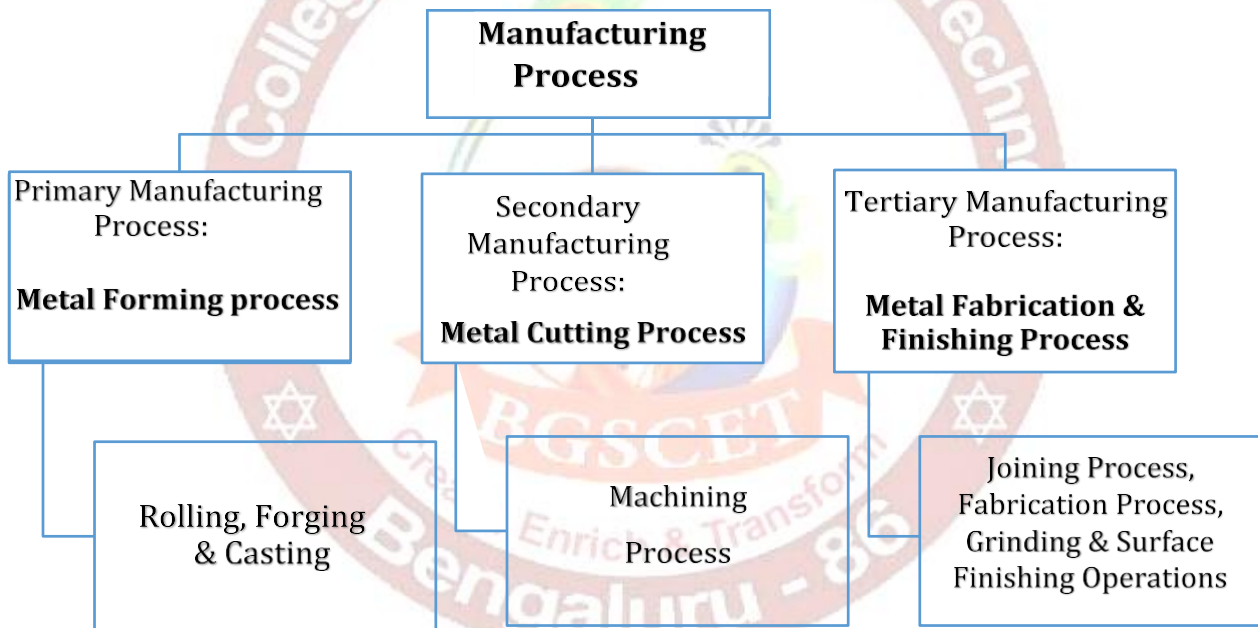

Figure: Block diagram of Classification of manufacturing Process

In metal forming process, no material is removed, but it is forced to change its size and shape by applying external pressure.

In metal cutting process, extra amount of material is removed from the work piece in the form of chips. The material removed due to the relative motion between the cutting tool and the work- piece.

Machine Tools:

When machines perform the metal cutting operations by the cutting tools mounted on them, they are called “Machine tools”. A machine tool may be defined as a power-driven machine that accomplishes the cutting or machining operations on it. The machine tools used for most of the machining processes are Lathe, Drilling, Milling, and Grinding machines.

Lathe Machine Tool:

The Lathe is one of the oldest machine tools used to produce cylindrical objects. The modern engine lathe is first developed in the year 1797 by an Englishman Henry Maudslay. The main function of the lathe is to remove metal from a work piece to give it the required shape and size. This is accomplished by holding the work securely and rigidly on the machine and then turning it against a cutting tool which will remove the material from the work in the form of a chip. To cut the material properly, the tool should be harder than that of the material of the work piece.

- Lathe is the oldest of all machine tools and perhaps the most basic tool used in industries. **A lathe is a machine tool that holds the work piece between two rigid and strong supports called centers or in a chuck.**
- The cutting tool is rigidly held and supported in a tool post which is fed against the revolving work.
- The normal cutting operations are performed with the cutting tool fed either parallel or at right angles to the axis of the work.
- The cutting tool may also be fed at an angle relative to the axis of work for machining tapers and angles.

Principle working of a Lathe Machine Tool:

Lathe machine is one of the most important machine tools which is used in the metalworking industry. It operates on the principle of a rotating work piece and a fixed cutting tool. The cutting tool is fed into the work piece which rotates about its axis causing the work piece to form the desired shape.

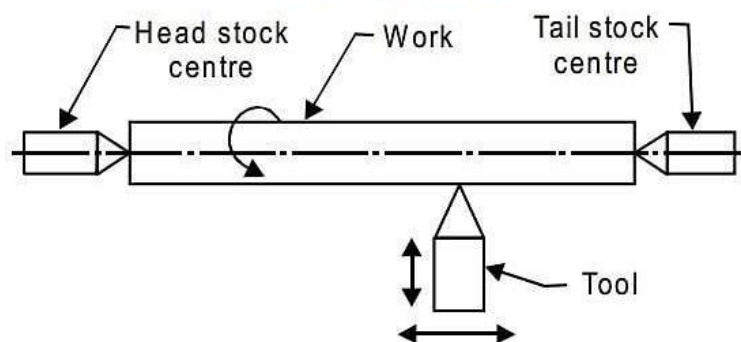

Figure: Principle of turning operation on Lathe

Classification of Lathe Machine Tools:

Lathes are classified based on their design, construction and application. Following are some of the important lathes used in industries.

1. Speed Lathe
2. Engine Lathe
3. Bench Lathe
4. Tool Room Lathe
5. Capstan & Turret Lathe
6. Special Purpose Lathe
7. Automatic Lathe
8. CNC Lathe (Turning Centers)

Construction & Working Principle of Centre Lathe/ Engine Lathe:

The schematic arrangement of the Centre or Engine Lathe is as shown in the following figure. The major parts of a center lathes are:

1. Bed & Guideways
2. Headstock
3. Tailstock
4. Lathe bed
5. Carriage Assembly
6. Driving mechanism & Feeding mechanism

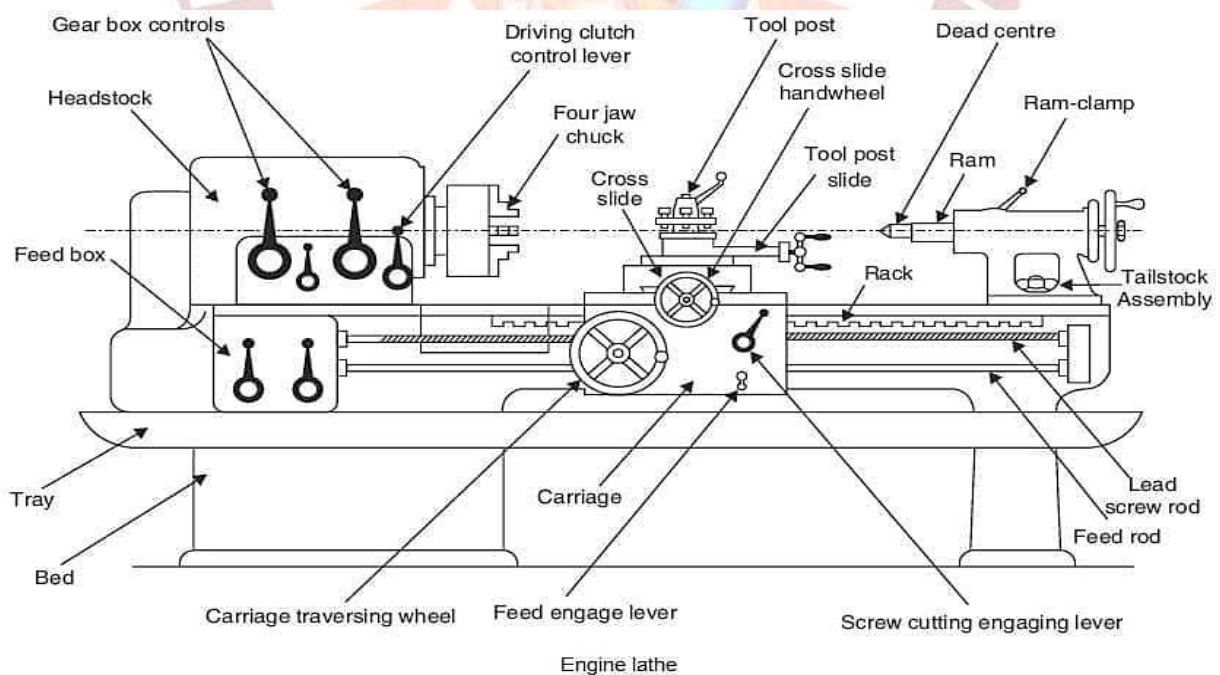

- **Bed:** Usually made of cast iron. Provides a heavy rigid frame on which all the main components are mounted.

It is the foundation part of a lathe and supports the remaining parts. The top of the bed is formed by precision-machined guide ways.

- **Guide Ways:** Inner and outer guide rails that are precision machined parallel to assure accuracy of movement.
- **Headstock:** mounted in a fixed position on the inner ways, usually at the left end. Using a chuck, it rotates the work. The housing comprising the feed gearbox and the cone pulley is called headstock of the lathe. The main spindle projects out from the headstock. The motor drives the cone pulley and drives the main spindle through belting. Spindle speeds can be further varied using the beek gear mechanism.
- **Gearbox:** inside the headstock, providing multiple speeds with a geometric ratio by moving levers.
- **Spindle:** Hole through the headstock to which bar stock can be fed, which allows shafts that are up to 2 times the length between lathe centers to be worked on one end at a time.
- **Chuck:** allows the mounting of difficult work pieces that are not round, square or triangular. 3-jaw (self-centering) or 4-jaw (independent) to clamp part being machined.
- **Tailstock:** Fits on the inner ways of the bed and can slide towards a headstock to fit the length of the work piece. Tailstock is the movable part of the lathe that carries the dead center in it. The main function of the tailstock is to support the free end of the long work pieces. It is mounted loosely on the bed ways and can be moved in the desired direction an optional taper-turning attachment would be mounted to it.
- **Carriage Assembly:** Moves on the outer ways. Used for mounting and moving most the cutting tools. The carriage assembly consists of.
 - **Saddle:** is an H-shaped casting slide over the outer set of guide ways and serves as the base for the cross slide.
 - **Cross slide:** is mounted on the saddle and enables the movement of the cutting tool laterally across the lathe bed using cross-feed hand wheel.
 - **Compound Rest:** is mounted on the top of the cross slide and is swiveled to any angle in the horizontal plane to facilitate taper turning and thread cutting operations.
 - **Apron:** is mounted in front of the saddle beneath it and houses the carriage and cross slide mechanisms.
 - **Tool Post:** is mounted in the T-Slot of the compound rest and properly clamps the cutting tool.
 - **Feed Rod:** Has a keyway, with two reversing pinion gears, either of which can be meshed with the mating bevel gear to forward or reverse the carriage using a clutch, is a stationary rod mounted in front of lathe bed and facilitates longitudinal movement of the carriage.
 - **Lead Screw:** is the screw rod that runs longitudinally in front of the lathe bed. The gyration of the lead screw moves the carriage to and fro longitudinally during thread cutting operations.

Lathe operations or Machining process on LATHE

The operations that can be performed on a lathe are

a) By holding the job between centers or between chuck and dead center

1. Facing
2. Turning
3. Step turning
4. Taper turning
5. Knurling
6. Thread cutting
7. Drilling
8. Counter sinking
9. Contour forming
10. Boring etc.

1. Facing: This is the operation of machining the ends of a work piece to produce a flat surface perpendicular to the axis. This is also used to cut the work to the required length. The operation involves feeding the tool perpendicular to the axis of rotation of the work piece. A regular cutting tool may be used for facing a work piece. The cutting edge should be set at the same height as the center of the work piece. A properly ground-facing tool is mounted in the tool post to accomplish facing operation.

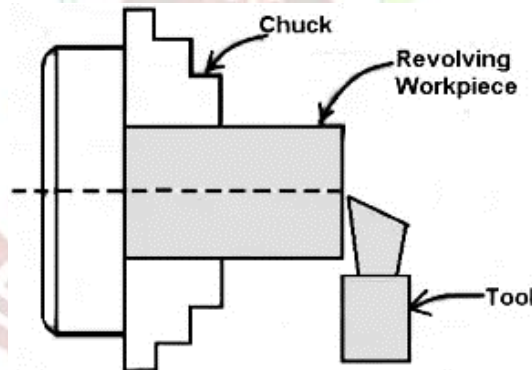

Facing Operation

2. Turning Operation: The process of metal removal from the cylindrical jobs is called straight or plain turning. Cross-slide and the carriage are used to perform turning operation and make the operation faster and economical. The work-piece is supported in-between the two centers which permit the rotation of the work-piece. A single point cutting tool is fed perpendicular to the axis of the work-piece to a known predetermined depth of cut, and is then moved parallel to the axis of the work-piece.

Plain turning operations are generally performed in two steps-rough and finish turning. Rough turning is usually done for rolled, cast or forged parts to remove the uneven or sandy or rough surface on the jobs. A roughing tool does roughing and used for excess stock removal. For finishing a tool with slightly round cutting edge is used. The depth of cut rate is at the range of 0.2 to 1 mm and the feed rate between 0.1 to 0.3 mm.

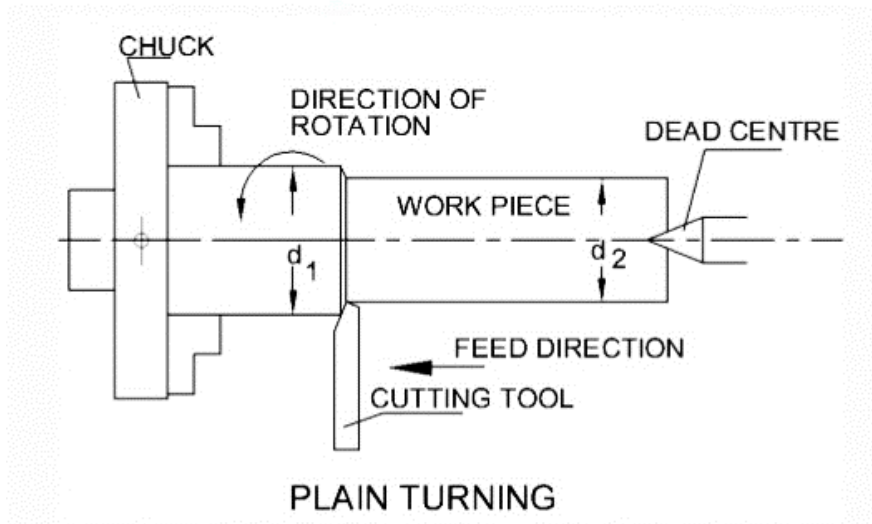

3. Knurling: Knurling is an operation performed on the lathe to generate a serrated surface on the work piece. This is used to produce a rough surface for gripping like the barrel of the micrometer or screw gauge. This is done by a special tool called knurling tool which has a set of hardened rollers with the desired serrations. As shown in figure (a) and figure (b)

- During the knurling operation, the hardened rollers of the tool are pressed against the slowly rotating work pieces such that the impression of tool serrations is formed on the work piece surface.
- Usually, there are three different patterns of knurling produced as per requirements and as shown.
 - Figure: Knurling operations

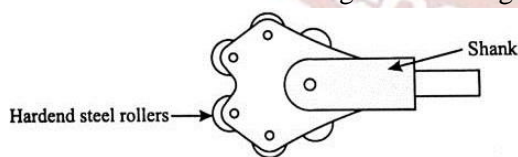

Figure (a): A typical knurling tool

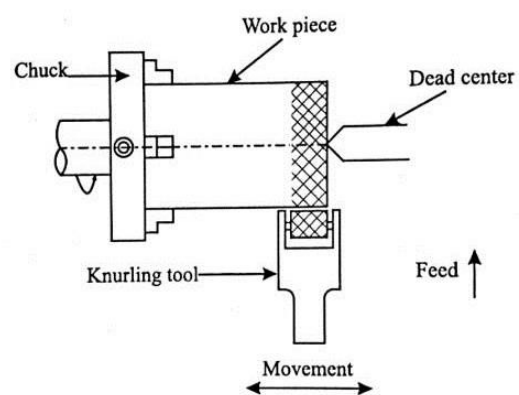
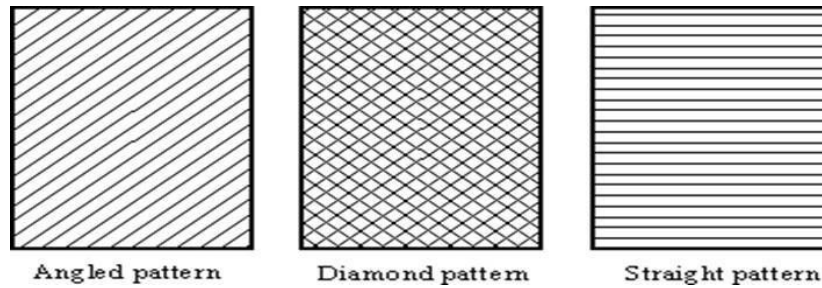

Figure (b): Knurling operation

Figure: Knurling operation



4. Taper Turning: Taper turning is a machining process for producing a conical surface on a cylinder work piece as shown figure below.

- The work piece is held rigidly between the two supports of the machine and the cutting tool is fed against the revolving work piece at an angle to the lathe axis, operation on a lathe to produce a conical surface on the work pieces.

Methods of Taper Turning.

- Swiveling the compound rest.
- Offsetting the Tailstock

a) Taper turning by Swiveling the compound rest.

- In this method compound rest is swiveled to the required taper angle and then locked in the angular position. Figure Shown below.
- The carriage is also locked in that position
- For taper turning the compound rest is moved linearly at an angle so that the cutting tool produces the tapered surface on the work piece.
- This method is suitable for limited lengths due to the limited movement of compound rest

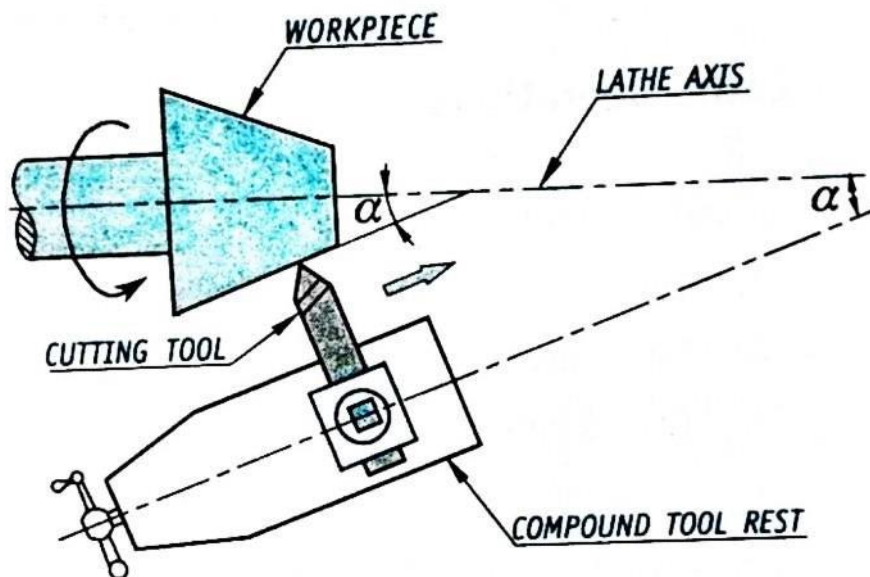
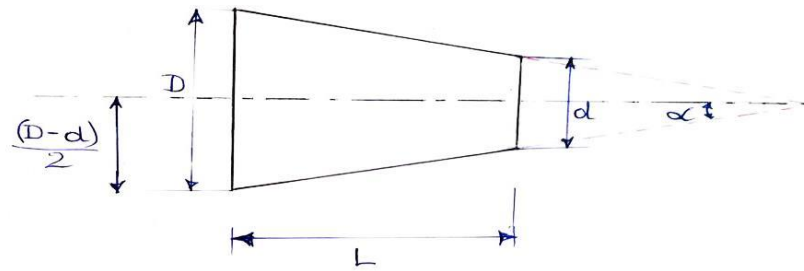

Fig. Taper turning by Swiveling the compound rest.



Where, D = Bigger diameter of the taper (mm)
 d = Smaller diameter of the taper (mm)
 L = Length of the taper (mm)
 α = half – tapered angle

Half – tapered angle is calculated using the equation:

$$\tan \alpha = \left(\frac{\frac{D-d}{2}}{L} \right)$$

$$\text{Half – taper angle} = \alpha = \tan^{-1} \left(\frac{D-d}{2L} \right)$$

a) Taper Turning by Offsetting the Tailstock.

- This method is also known as set over tailstock method. Figure shown below
- In this method the tailstock center is set out of alignment, the work piece gets taper because its axis will be inclined at an angle with the longitudinal movement of the tool which will be parallel to the lathe bed. As shown in figure below.
- The cutting tool is fed parallel to the lathe axis and the desired taper is produced.

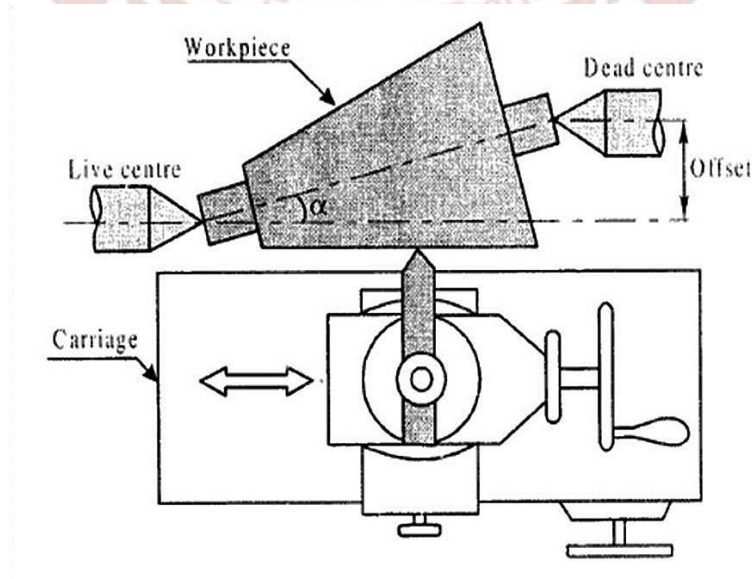
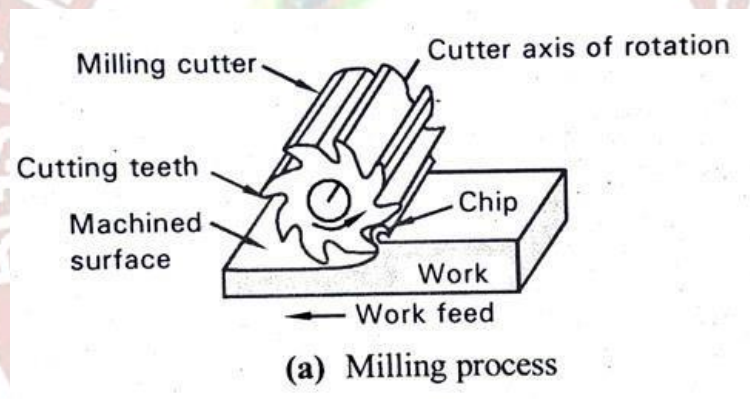

Fig. Taper Turning by Offsetting the Tailstock

INTRODUCTION TO MILLING

- Milling is a process of shaping work materials by feeding the work material against a multipoint rotating cutter. As shown in figure.
- The machine used for the purpose is called milling machine. Milling can be used for producing flat, angular, or curved surfaces, for cutting threads, toothed gears, keyways, slots, and a wide variety of other operations.
- The milling cutter is a multipoint cutting tool. The work piece is mounted on a movable worktable which will be fed against the revolving milling cutter to perform the cutting operation.
- A milling machine is a power-operated machine tool in which the work piece mounted on a moving table is machined to various shapes when moved under a slow revolving multipoint cutter.
- The difference between drilling and milling is that, in drilling a rotating drill is fed against a stationary work piece, while in milling the work piece is fed against a milling cutter which only revolves.
- Similarly, it also differs from the lathe operation because the lathe tool is fed against a rotating work piece.



THE PRINCIPLE OF MILLING

- In milling, the cutter is held in the spindle of the machine and made to rotate at suitable speeds.
- The work piece is also held rigidly by a suitable device and is fed slowly against the rotating cutter.
- The work piece can be fed in two different directions with respect to cutter rotation as shown in figure. below the process thus gives a means of classification of milling into two types known as up milling and down milling.
- In up milling process as shown in figure (a), the work piece is fed in the direction opposite to that of the rotating cutter, while in down milling process as shown in figure (b), the work piece is fed in the same direction as that of the rotating cutter.
- The various aspects related to the two types are tabulated in a comparison form in table.

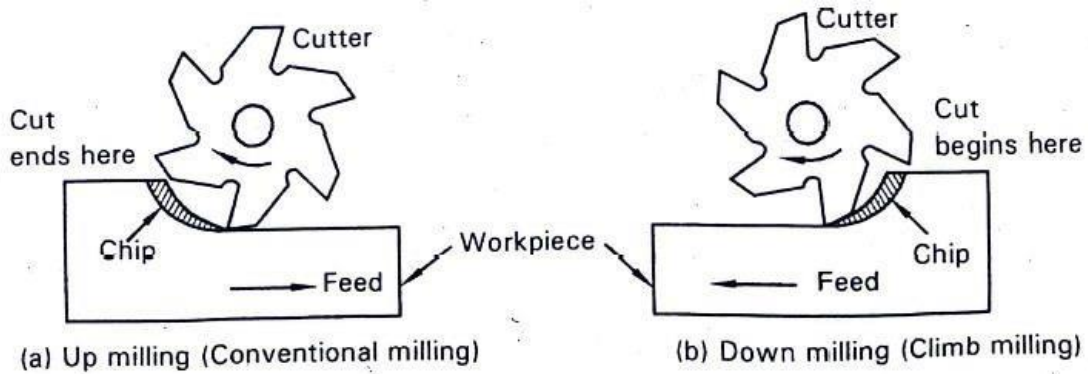

Comparison between Up Milling and Down Milling

Sl. No.	Up milling (Conventional milling)	Down milling (Climb milling)
1.	In up milling, the work piece is fed in the direction opposite to that of the rotating cutter.	In down milling, the work piece is fed in the same direction as that of the rotating cutter.
2.	The thickness of the chip is minimum at the beginning of the cut and reaches to a maximum when the cut ends.	The thickness of the chip is maximum at the beginning of the cut and reaches the minimum when the cut ends.
3.	In up-milling, the cutting force is directed upwards. This tends to lift the work piece from the worktable. Hence, a greater clamping force for the work piece becomes necessary.	The cutting force is directed downwards, and this tends to keep the work piece firmly on the work table there by permitting lesser clamping forces.
4.	During up-milling, the chip gets accumulated at the cutting zone (tool-work interface). These chips interfere with the rotating cutter thereby impairing the surface finish on the work surface.	In down milling, the chips do not interfere with the revolving cutter, since they are disposed of easily by the cutter. Hence, there is no damage to the surface finish of the work piece.
5.	In up milling, it is difficult for efficient circulation of coolant. The cutter rotating in the upward direction carries away the coolant from the cutting zone.	In down milling, the coolant can easily reach the cutting zone. Hence, efficient cooling of the tool and the work piece can be achieved.
6.	Up milling is preferred for rough cuts, especially for castings and forgings, because this method enables the cutter to dig-in and start the cut below the hard upper surface.	Down milling produces better surface finish because there is no dig-in of the cutter. It is particularly used for finishing operations and small work like cutting slots, grooves etc.

Types of Milling Machines

The different types of milling machines are listed as follows.

Column and knee milling machines.

- a) Plain column and knee type milling machines
 - Horizontal or plain type of milling machine
 - Vertical Milling machine
 - Universal Milling machine

Horizontal Milling Machine

It is one of the most popular types of milling machine, and is commonly called horizontal milling machine, because of the horizontal position of the spindle. This type of machine is used to cut grooves, slots, keyways, gear teeth etc. Figure shows one of the principal views of a horizontal milling machine.

The milling machine has some principal parts. Their understanding would help us in understanding how the machine operates. The various parts are

The machine consists of the following parts:

- a) **Base** is usually a strong and hollow part that forms the foundation of the machine and upon which all the other parts are mounted. The base also serves as a sump for the cutting fluid. A pump and filtration system can be installed in the base. The hole provided in the center of the base houses the support for the elevating screw that raises and lowers the knee.
- b) **Column** is a vertical hollow casting and is usually combined with the base to form a single casting. The column houses the spindle and bearings as well as the drive units (gears, clutches, shafts, and shifting mechanisms) for transmitting power from the electric motor to the spindle at desired speeds. The front face of the vertical column is provided with square or dovetail-type guideways on which the knee slides up and down.
- c) **Spindle** is a hollow shaft supported by the column with suitable bearings that absorb both radial and thrust loads. The spindle is made hollow and tapered inside to accept standard arbors. The spindle obtains power from the motor and transmits it to the arbor. The arbor carrying the cutter rotates about a horizontal axis.
- d) **Overarm** mounted on the vertical column supports the yoke, which in turn supports the free end of the arbor.
- e) **Knee** is a casting that slides up and down on the vertical guideways provided on the column by means of an elevating screw. The knee supports the saddle.

f) **Saddle** mounted on the knee is provided with two slides (guideways) on its top and bottom surfaces. The slides are machined at right angles to each other. The lower slide fits the slide provided on top of the knee and facilitates horizontal movement of the saddle.

The upper slide provided on the saddle accepts the slide provided on the bottom surface of the worktable.

g) **Worktable** is larger and rests on the saddle. The bottom surface of the table has a dovetail slide that fits in the slide on the top surface of the saddle. This arrangement facilitates the worktable to be moved longitudinally or at right angles to the movement of the saddle. The worktable is provided with T-slots all along its length for mounting vice or other work-holding devices. This enables the work piece to be clamped rigidly on the table. The worktable may be manually controlled or power-fed. A dial graduated in thousandths of an inch (not shown in the figure) is provided to allow for accurate table movement and placement.

h) **Arbor**: The arbor is a horizontal shaft provided with a straight body and tapered shank. On the straight portion of the arbor, rotary cutters are mounted. The tapered end of the arbor fits into the tapered hole of the spindle. The other end of the arbor is mounted in a bearing housed in the projecting overarm.

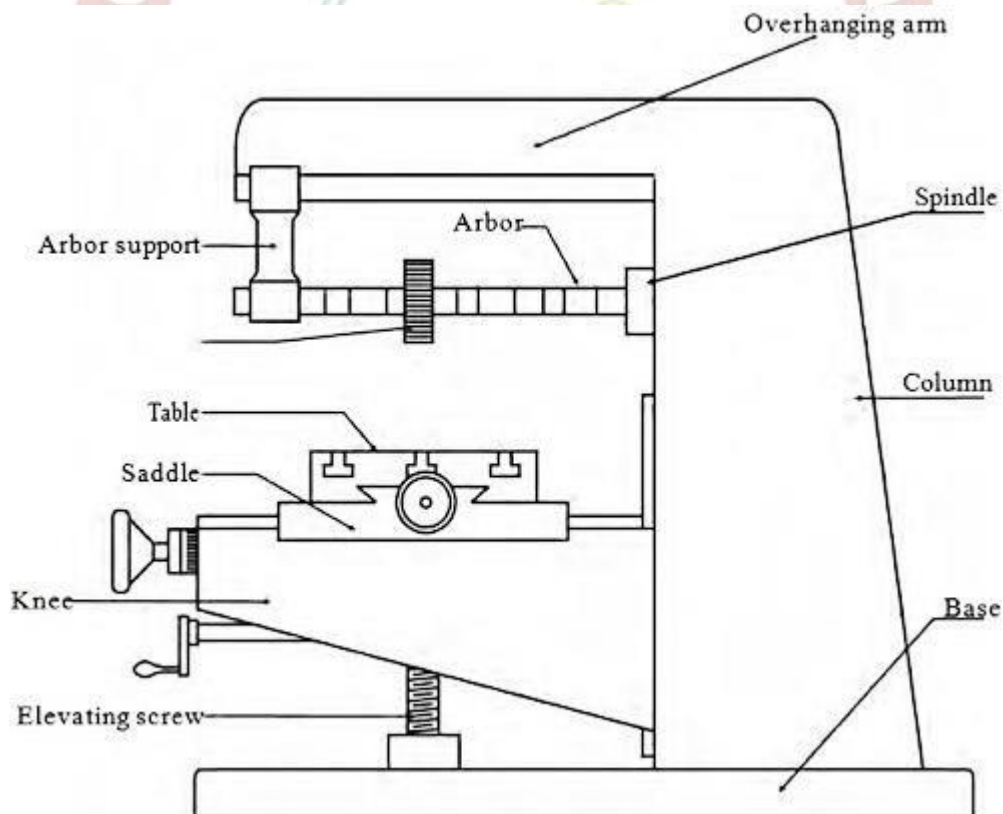

Figure: Horizontal / Column & Knee type milling machine

Milling machine Operations:

A variety of milling operations are performed on a milling machine to produce a horizontal, vertical, inclined surfaces, keyways, slots, gear teeth etc., A few of the most commonly used milling operations are described here.

1.Slab Milling

This method is also called as plain milling. The plain milling is the most common types of milling machine operations.

- Slab milling is performed to produce a plain, flat, horizontal surface parallel to the axis of rotation of a plain milling cutter.
- The operation is also known as slab milling.
- To perform the operation, the work and the cutter are secured properly on the machine.
- The depth of cut is set by rotating the vertical feed screw of the table. And the machine is started after selecting the right speed and feed.

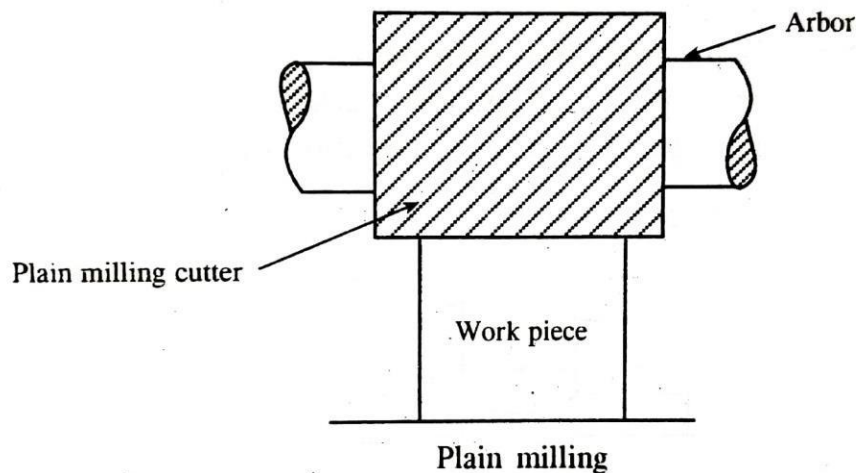

2. Slot Milling

The slot milling, also called as groove or keyway cutting is done on a horizontal milling cutter or using an end milling cutter.

- The operation of producing of keyways, grooves and slots of varying shapes and sizes can be performed in a milling machine.
- It is done by using a plain milling cutter, a metal slitting saw, an end mill or by a side milling cutter.
- The open slots can be cut by a plain milling cutter, a metal slitting saw, or by a side milling cutter. The closed slots are produced by using end mills.

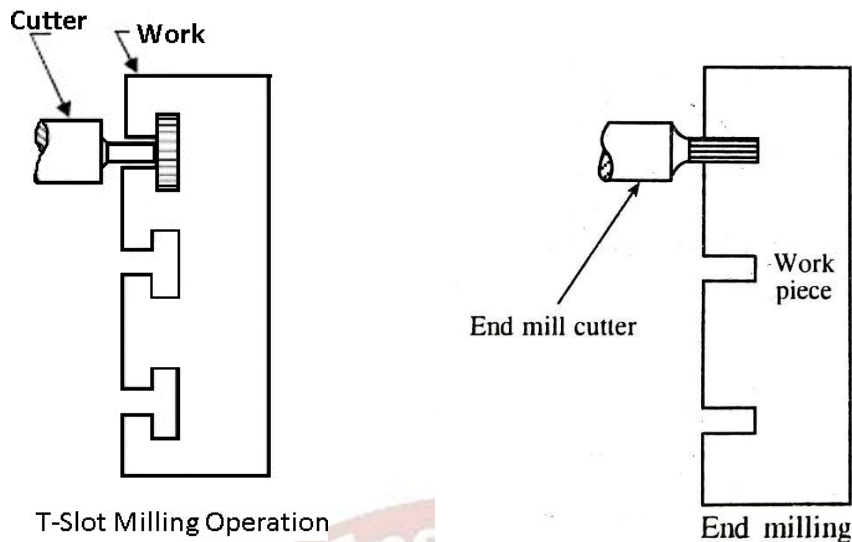

3. Face Milling

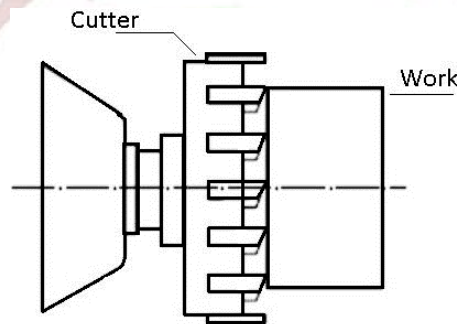

Figure: Face Milling operation

In this method, the flat surfaces are milled by the cutters, which are mounted with their axis perpendicular to the milled surfaces.

- The face milling is the simplest milling machine operations.
- This operation is performed by a face milling cutter rotated about an axis perpendicular to the work surface.
- The operation is carried in plain milling, and the cutter is mounted on a stub arbor to design a flat surface.
- The depth of cut is adjusted by rotating the cross-feed screw of the table.

4. Angular Milling

In this method, inclined surfaces are produced by milling cutters having their teeth inclined to their axis. Dovetail grooves and V-guides are machined by this method.

- The angular milling is the operation of producing an angular surface on a work piece other than at right angles of the axis of the milling machine spindle.

- The angular groove may be single or double angle and may be of varying included angle according to the type and contour of the angular cutter used.
- One simple example of angular milling is the production of V-blocks.

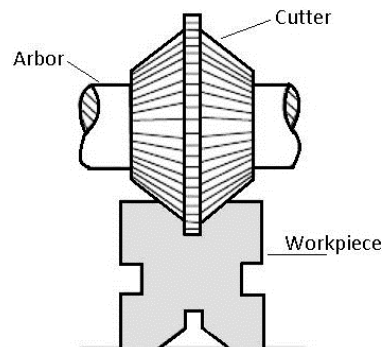

Figure: Angular Milling

5. Form Milling

In this method, surfaces having irregular profiles are milled by suitable cutters.

- The form milling is the operation of producing the irregular contour by using form cutters.
- The irregular shape may be convex, concave, or of any other shape. After machining, the formed surface is inspected by a template gauge.
- The cutting rate for form milling is 20% to 30% less than that of the plain milling.

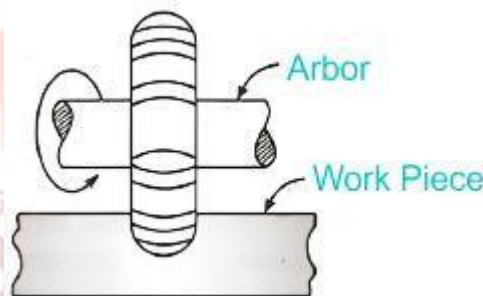
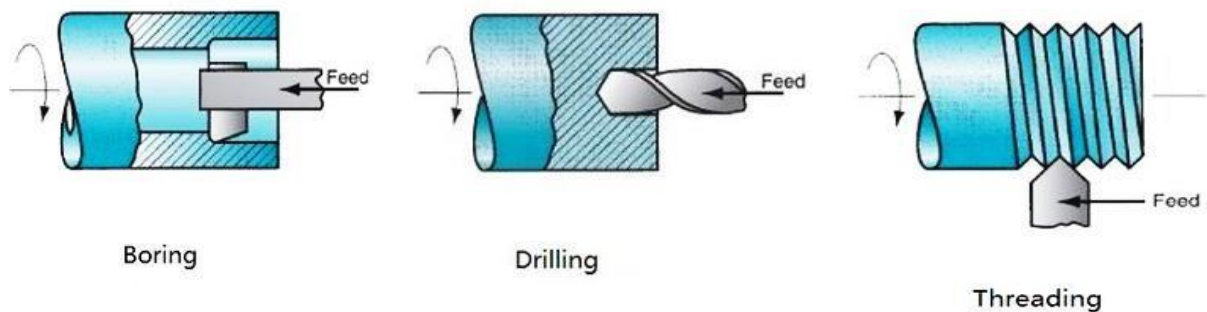

Figure: Form Milling

Other Lathe Operations:



Drilling Machine Tool

Introduction

- Drilling is a machining operation of producing a cylindrical hole in a solid work piece by means of a revolving tool called drill bit.
- The tool is also called twist drill since it has sharp twisted edges formed around acylindrical body. Figure shows the drilling operation.
- In operation, the drill bit is held rigidly in the chuck of the machine and rotated by the spindle at high speed.
- With the help of a hand wheel or by automatic means, the drill bit is forced to move against the rigidly clamped work piece.
- A hole is generated by the sharp cutting edges of the rotating drill bit and meanwhile, the excess material removed (chips) gets curled and escapes through the helical grooves provided in the drill bit.
- Although drilling seems to be a simple process, it is actually a complex one. The tool apart from performing the cutting action also extrudes the cut material (chips) from the work piece.
- Since the cutting action takes place inside the work piece, a lot of heat generated is minimized by circulating a suitable coolant.

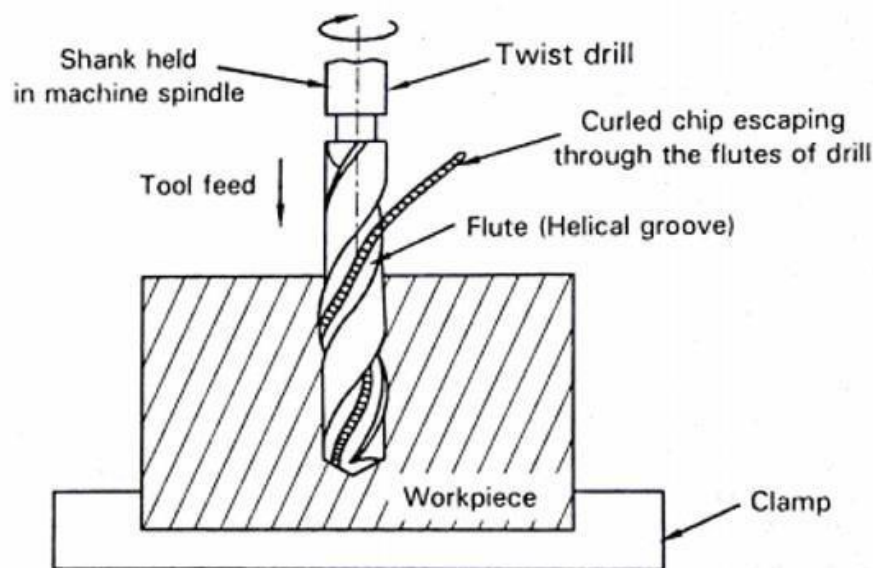

Figure: Drilling Operation

Types of drilling machines

Drilling machines are manufactured in different types and sizes according to the type of operation, amount of feed, depth of cut, spindle speeds, method of spindle movement and the required accuracy.

The different types of drilling machines are:

1. Portable drilling machine (or) Hand drilling machine
2. Sensitive drilling machine (or) Bench drilling machine

3. Upright drilling machine
4. Radial drilling machine
5. Gang drilling machine
6. Multiple spindle drilling machine
7. Deep hole drilling machine

Upright drilling machine

The upright drilling machine is designed for handling medium sized work pieces. Though it looks like a sensitive drilling machine, it is larger and heavier than a sensitive drilling machine. Holes of diameter up to 50mm can be made with this type of machine. Besides, it is supplied with power feed arrangement. For drilling different types of work, the machine is provided with a number of spindle speeds and feed.

Base

The base is a rectangular casting made of cast iron and so can withstand vibrations. It is mounted on the floor. It supports all the other parts of the machine on it.

Column

The column stands vertically on the base at one end. It supports the work table and the drill head. The drill head has drill spindle and the driving motor on either side of the column.

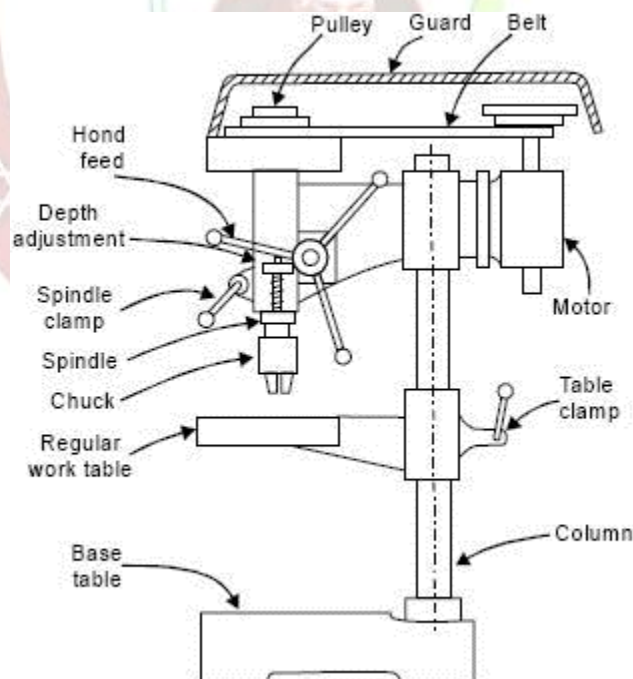

Table

The table is mounted on the vertical column and can be adjusted up and down on it. The table has 'T'-slots on it for holding the work pieces or to hold any other work holding device. The table can be adjusted vertically to accommodate work pieces of different heights and can be clamped at the required position.

Drill head

Drill head is mounted on the top side of the column. The drill spindle and the driving motor are connected by means of a V-belt and cone pulleys. The motion is transmitted to the spindle from the motor by the belt. The pinion attached to the handle meshes with the rack on the sleeve of the spindle for providing the drill the required down feed.

Radial drilling machine

- Radial drilling machines are used for drilling medium or large diameter holes of up to 50 mm in heavy work pieces. Figure shows the principal parts of a radial drilling machine.

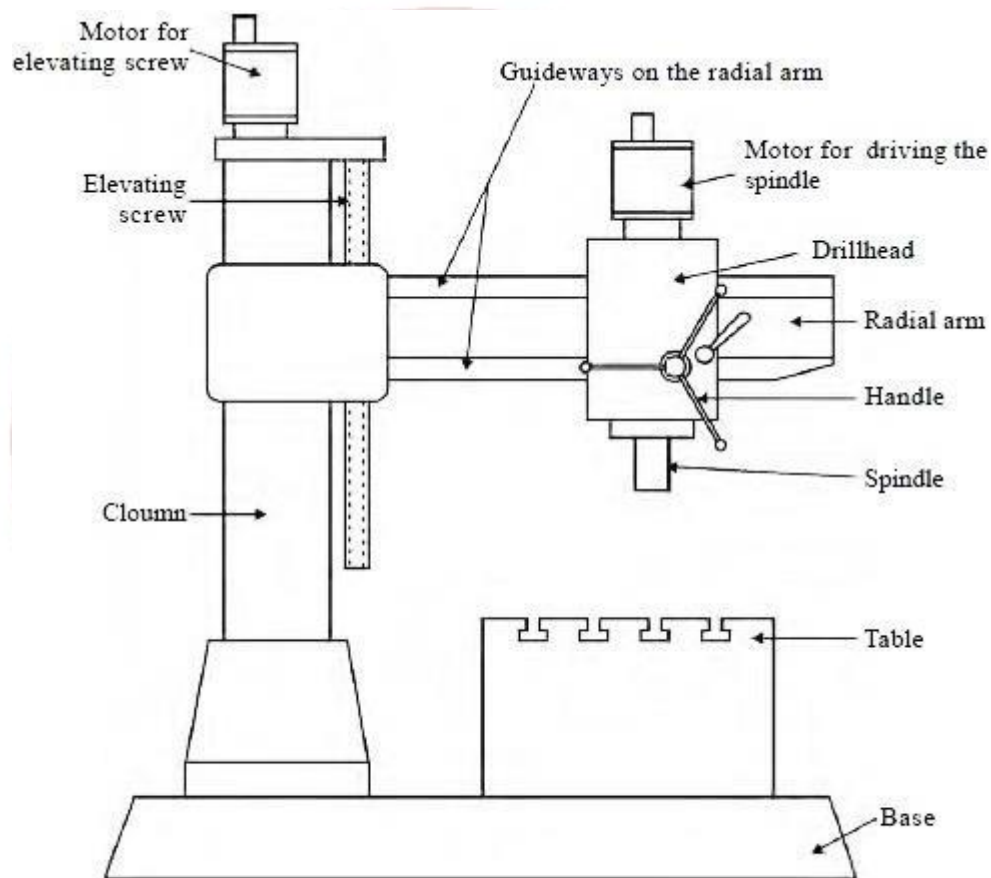

Radial drilling machine

The machine consists of the following parts:

a) Base

- The base of the machine is a large cast iron material on which is mounted a cylindrical vertical column.
- The base is provided with T-slots, which help the work piece to be clamped rigidly to the base of the machine.

b) Vertical column

- The column is a long, cylindrical shaped part fastened rigidly to the base.
- The column carries a radial arm that can be raised or lowered by means of an electric motor and can be clamped to any desired position. The radial arm can also be rotated (swiveled) in a complete circle around the column.
- (A drill chuck holds the cutting tool of any size, whereas a socket is used to hold a tool of a particular shank size.)

c) Drill head

- The drill head is mounted on the radial arm and carries a driving motor and a mechanism for revolving and feeding (power feed) the drill bit into the work piece.
- The drill head can be moved horizontally on the guideways provided in the radial arm and can be clamped to any desired position.
- With the combination of the movements of the radial arm and the drill head, it is possible to move the drill bit and hence generate a hole at any desired position without moving the work piece.

Drilling machine operations

Though drilling is the primary operation performed in a drilling machine, several similar operations are also performed on jobs using different tools. The different operations that can be performed in a drilling machine are:

1. Drilling
2. Reaming
3. Boring
4. Counter boring
5. Countersinking
6. Spot facing
7. Tapping
8. Trepanning

1. Drilling:

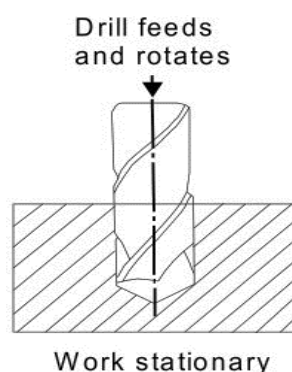

Drilling can be called as the operation of producing a cylindrical hole of required diameter and depth by removing metal by the rotating edges of a drill. The cutting tool known as drill is fitted into the spindle of the drilling machine. A mark of indentation is made at the required location with a center punch. The rotating drill is pressed at the location and is fed into the work. The hole can be made up to a required depth.

2. Reaming:

Reaming shown in Figure, is an accurate way of sizing and finishing a hole which has been previously drilled. In order to finish a hole and to bring it to the accurate size, the hole is drilled slightly undersize. The speed of the spindle is made half that of drilling and automatic feed may be employed. The tool used for reaming is known as the reamer which has multiple cutting edges. Reamer cannot be used to drill a hole. It simply follows the path which has been previously drilled and removes a very small amount of metal.

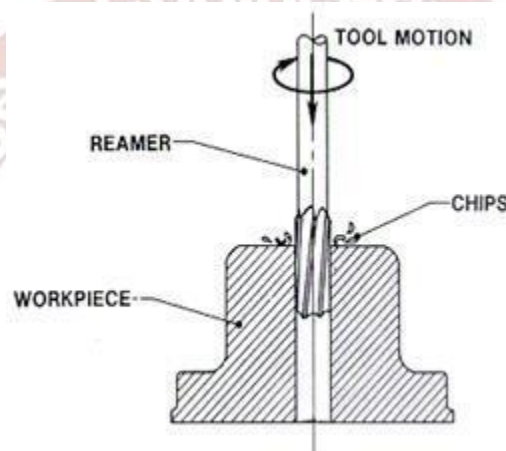

3. Boring

Boring is the operation of enlarging the size of the previously drilled hole. For this purpose a special purpose cutting tool is used. Boring operation is also carried out to finish a hole accurately and to bring it to the required size.

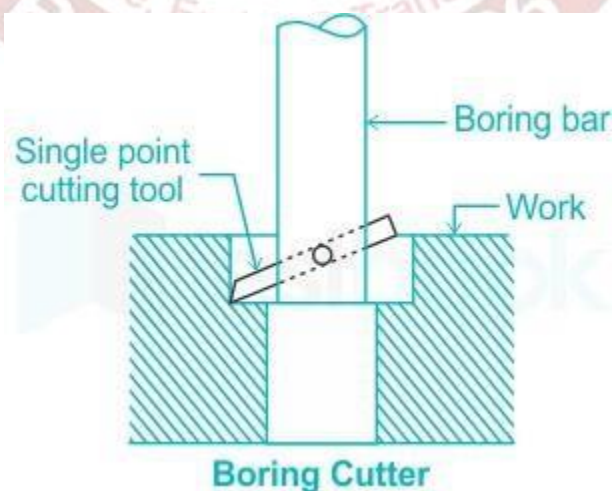

Applications of Drilling Machines

- The basic function of drill machine is to construct hole of different size in solid materials.
- Different drills are used for industry particular applications.
- Drill rigs are used to drill water wells and oil wells.
- Hand drills are used for screwing and fastening.
- Electrical pistol grip drill is used in general masonry workings by builders, electricians and plumbers.
- Hammer drill is particularly used by carpenters to drill and fix the wooden parts.
- These machines are used in industries like manufacturing, metalworking, woodworking, masonry and construction as well.
- Apart from drilling holes, drill machine is featured of performing a variety of tasks like tapping, spot facing, reaming, counter sinking and counter boring etc.



Introduction to Advanced Manufacturing Systems

COMPUTER NUMERICAL CONTROL (CNC)

Introduction: Computer Numerical Control or CNC is an advanced form of the NC system where the machine control unit is a dedicated microcomputer instead of a hard-wired controller, as in conventional NC.

Computer Numerical Control has evolved during the rapid improvements of the computer technology. The advent of Microprocessors from the 1970s have helped in quick advancements in the Computer Technology and is in turn adapted in modern CNC Technology.

Today's CNC Controller has latest features like high speeds of operation, large memories, bus architectures, improved servos, etc.

CNC Technology has powered the Machine Tool industry today. It is used in majority of machine tools like machining centers, turning centers, grinders, lathes, drilling machines, etc.

COMPONENT OF A CNC SYSTEM

A CNC System consists of the following elements:

- 1) Input device
- 2) MCU or machine control unit
- 3) Machine tool
- 4) Driving System
- 5) Feedback devices
- 6) Display Unit

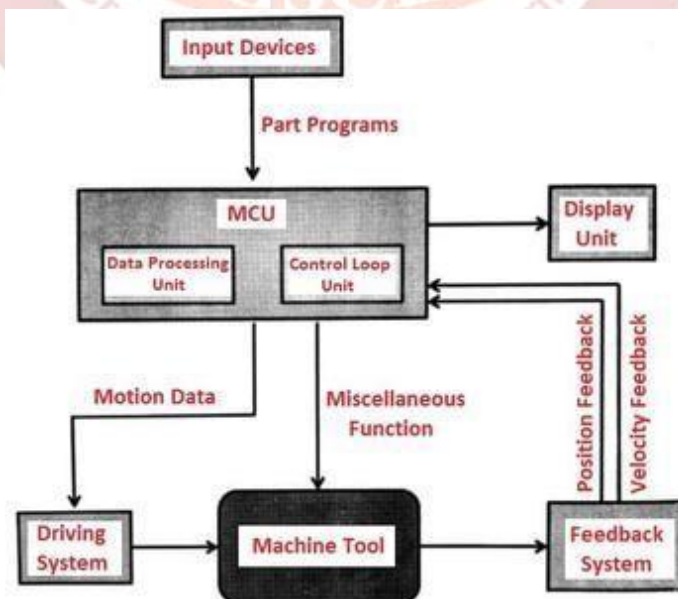

Basic Elements of CNC Machine

1. INPUT DEVICE:

The part program is entered into the CNC Control or the MCU through the input device.

There are various input devices used on a CNC Machine such as

- a) **USB (Universal Serial Bus) Flash drive:** Here the USB flash drives transfer data to the control. USB is very common nowadays and its use is increased in modern computers.
- b) **Serial Communication:** A serial communication port connects a computer system and a CNC Machine tool through an interface called RS-232. Most machines have RS-232 port and an RS-232 cable connects the computer and the CNC Machine to transfer data from the computer to the CNC Machine.
- c) **Ethernet Communication:** Ethernet communication is a more reliable and efficient means of transferring part programs from the Computer to the CNC Control.
- d) **Conversational Programming:** This is another way to input part programs to the controller through a keyboard. Built-in intelligent software inside the controller enables the operator to enter step-by-step data.

2. MCU OR MACHINE CONTROL UNIT:

The Machine Control Unit or the MCU is the heart of the CNC System. It consists of the following components:

- a) **Central Processing Unit:** The CPU is the brain of the MCU and it is comprised of
 - i). **a control section** that retrieves data from the memory and generates signals which in turn activates all MCU components.
 - ii). **An ALU (Arithmetic Logic Unit)** that performs integer arithmetic operations like addition, subtraction, multiplication, counting, etc. and logical operations.
 - iii). **Immediate Access Store or Immediate Access Memory:** This holds the data and programs temporarily that is required at that instant by the control section.
- b) **CNC Memory:** The memory of the CNC is divided into
 - i). **Main Memory** which consists of Read Only Memory (ROM) and Random Access Memory (RAM). The ROM stores the Operating System Software and machine interface programs. The RAM stores the Part programs.
 - ii). **Secondary Memory** such as Hard disks which is used to store large programs and which can be used by the main memory when required.
- c) **Input/output Interface:**
 - i). The Input/output interface or the I/O interface establishes communication between the machine operator, the components of the CNC system and other connected computers.

- ii). The Operator control panel is the interface through which the machine operator communicates with the CNC system. A keyboard and a display screen are also included in the panel.

d) Machine tool controls:

- i). A Machine Tool consists of various axis such as X, Y, Z, A, B, C and a spindle which rotates at the designed RPM.
- ii). The position and velocity control of each of the axis and the rotational speed control are accomplished by certain hardware components in the MCU.
- iii). The MCU generates control signals that are transformed into a form suitable for the specific position control systems that is required to drive the various axis of the machine.

e) Sequence controls for auxiliary functions:

- i). Apart from the general functions like spindle speed, feed rate, etc., certain auxiliary functions like tool emergency stop, tool changing function, etc. are carried out under part control program controls.

3. MACHINE TOOL:

- This can be any type of machine tool such as a Machining center, a turning center, a lathe, a milling machine, etc.
- The essential parts of the machine tool include the machine table, machine slide, driving lead screw, ball screw, rigid and heavy machine Structure, automatic tool changing system, spindle, and spindle drive system, chip removal System, etc.
- The machine table is controlled on the X and Y axis, while the spindle runs along the Z axis.
- In other machine tools, there are additional axes such as A, B, or C that allow rotary motions around the X, Y, and Z axes.

4. DRIVING SYSTEM:

- A drive system essentially is made up of amplifier circuits, drive motors, and ball lead-screws. The control signals (position and speed) of each axis are fed by the Machine Control Unit (MCU) to the amplifier circuits.
- Then, the control signals are augmented to actuate drive motors which in turn rotate the ball lead-screws to position the machine table.
- The commonly used types of electrical motors include DC Servo Motor, AC Servo Motor, Stepping Motor and Linear Motor.

5. FEEDBACK DEVICES:

- For the accurate operation of a CNC Machine, the positional values and speed of the axis needs to be continuously updated.
- This is done by the feedback devices.

6. DISPLAY UNIT:

- The display unit is the device that ensures interaction between the machine operator and the machine.
- Display unit displays the current status of operation such as the spindle RPM, the running part program, the feed rate, position of the machine slide, etc.

Advantages of the CNC Machine Tool:

- The accuracy and repeatability obtained is high. Most aircraft parts are produced today on CNC machines
- Complex-shaped contours can be machined. Turbine blades, impellers, etc.
- Can be easily programmed to handle a variety of product styles
- High volume of production compared to conventional machines
- Lesser skilled or trained people can operate CNC machines unlike conventional ones where high skilled people are required
- CNC machines can be used uninterruptedly without turning them off provided regular maintenance is done
- Avoids errors that were otherwise committed by humans operating conventional machines
- Since CNC machines can be programmed, one person may well take care of a number of CNC machines. Reduces employees and hence costs are reduced
- Using CNC machines results in a safer work environment.

Disadvantages of the CNC Machine:

- Thorough programming knowledge is required by the operators or programmers.
- Skilled programmers required, cost of the labour can be high
- Cost of the CNC machine is high compared to the conventional machine tools
- Spares of CNC machines are relatively costlier than conventional machines
- CNC machines require air conditioned environment and /or a chiller unit. Thus extra costs are involved.

CNC Machining Centers:

- The term “machining centers” describes almost any CNC milling and drilling machine that includes an automatic tool changer and a table that clamps the work piece in place.
- CNC machine center is an advance manufacturing machine tool which performs wide range of machining operation with accuracy and good quality surface finish.
- The orientation of the spindle is the most fundamental defining characteristic of a CNC machining centers.

- CNC machining centers can further be classified based on the rotation of either the work piece or the rotation of the tool as:
 - CNC turning machines
 - CNC Milling machines

CNC Turning Centers:

- The primary function of a CNC Turning Center is that it rotates (or “turns”) your work piece.
- CNC Turning Machines are one of the oldest and simplest forms of machining parts, called “lathes,”.
- Can be either horizontal or vertical depending on the weight and tolerance of the work piece.
- Work-pieces for this process are usually round, but can be other shapes — like squares or hexagons.
- The work-piece is held in place by an instrument known as the “chuck.” The chuck then spins at various RPMs (depending on the capability of your machine).
- When this occurs, the machine’s tool moves into the rotating work piece and begins to shave away material to create the desired shape.



Figure: CNC Turning center and machining center

CNC Milling Centers/ Machining Centers:

- The primary function of a CNC Milling Machine is that your tool will be doing the rotating and moving while your work piece stays in one spot (generally).
- Milling is a more specific process that is similar to drilling and cutting.
- These machines can also be either horizontal or vertical, again depending on the tolerance and weight of your work piece.
- This process has many axes that allow for a variety of shapes, holes, and slots to be cut into the work piece at many angles.
- These axes provide many different maneuvers, either by the spindle or the bed, to cut the part desired to the exact specifications.

3D Printing

A method of manufacturing known as ‘Additive manufacturing’, due to the fact that instead of removing material to create a part, the process adds material in successive patterns to create the desired shape.

Main areas of use:

- Prototyping
- Specialized parts – aerospace, military, biomedical engineering, dental
- Hobbies and home use
- Future applications– medical (body parts), buildings and cars

3D Printing uses software that slices the 3D model into layers (0.01mm thick or less in most cases). Each layer is then traced onto the build plate by the printer, once the pattern is completed, the build plate is lowered and the next layer is added on top of the previous one.

Typical manufacturing techniques are known as ‘Subtractive Manufacturing’ because the process is one of removing material from a preformed block. Processes such as Milling and Cutting are subtractive manufacturing techniques. This type of process creates a lot of waste since; the material that is cut off generally cannot be used for anything else and is simply sent out as scrap. 3D Printing eliminates such waste since the material is placed in the location that it is needed only, the rest will be left out as empty space.

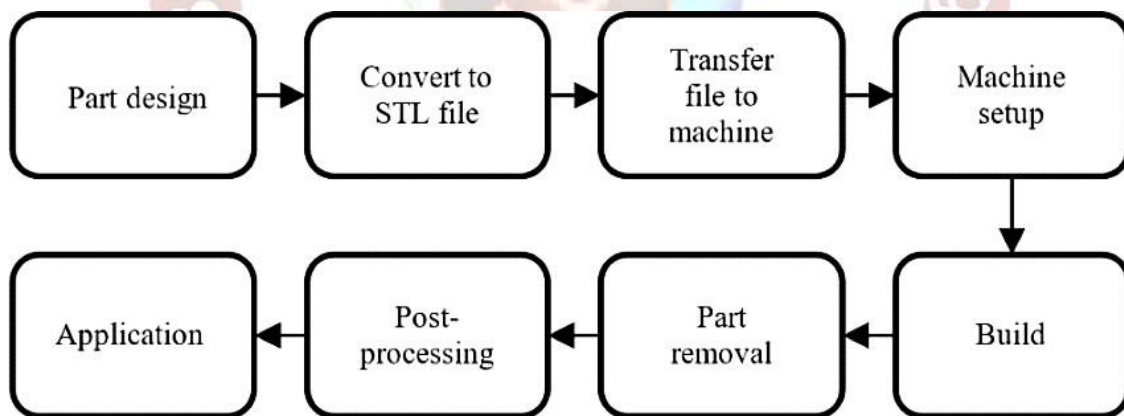

Basic Principles of Additive Manufacturing: (Steps of AM process)

AM involves 8 steps that move from the virtual CAD description to the physical resultant part

Step 1: CAD

All AM parts must start from a software model that fully describes the external geometry. This can involve the use of almost any professional CAD solid modeling software, but the output must be a 3D solid or surface representation. Reverse engineering equipment (e.g., laser scanning) can also be used to create this representation.

Step 2: Conversion to STL

Nearly every AM machine accepts the STL file format, which has become a de facto standard, and nearly every CAD system can output such a file format. This file describes the external closed surfaces of the original CAD model and forms the basis for calculation of the slices.

Step 3: Transfer to AM Machine and STL File Manipulation

The STL file describing the part must be transferred to the AM machine. Here, there may be some general manipulation of the file so that it is the correct size, position, and orientation for building.

Step 4: Machine Setup

The AM machine must be properly set up prior to the build process. Such settings would relate to the build parameters like the material constraints, energy source, layer thickness, timings, etc.

Step 5: Build

Building the part is mainly an automated process and the machine can largely carry on without supervision. Only superficial monitoring of the machine needs to take place at this time to ensure no errors have taken place like running out of material, power or software glitches, etc.

Step 6: Removal

Once the AM machine has completed the build, the parts must be removed. This may require interaction with the machine, which may have safety interlocks to ensure for example that the operating temperatures are sufficiently low or that there are no actively moving parts.

Step 7: Post processing

Once removed from the machine, parts may require an amount of additional cleaning up before they are ready for use. Parts may be weak at this stage or they may have supporting features that must be removed. This therefore often requires time and careful, experienced manual

Step 8: Application

Parts may now be ready to be used. However, they may also require additional treatment before they are acceptable for use. For example, they may require priming and painting to give an acceptable surface texture and finish. Treatments may be laborious and lengthy if the finishing requirements are very demanding.

Advantages of Additive Manufacturing Technologies:

1. **Variety is free** – Changing a part is simple and can be made easily in the original CAD file and the new print can be taken easily.
2. **Complexity is free** – Printing of a complex part costs less than simple cubes of the same size. The less solid or more complex object, it can be fatly and cheaply made through additive manufacturing.
3. **No need for assembly** – Hinges and bicycle chains are some of the moving parts that can be printed in metal directly into the product and thus reduce the part numbers.
4. **Little-skill manufacturing** – Professionals take care of the complicated parts with specific parameters and high-tech applications, children in elementary school have created their own figures by use of 3D printing processes.
5. **Few Constraints** – In CAD software one can dream of anything and design the same and create it with additive manufacturing.
6. **Various shades of materials** – In the CAD files, the engineers can program parts to have specific colors and printers can use materials of any color to print them.
7. **Lower energy consumption:** AM saves energy by eliminating production steps, using substantially less material, enabling reuse of by-products, and producing lighter products
8. **Less Waste:** Building objects up layer by layer, instead of traditional machining processes that cut away material can reduce material needs and costs by up to 90%. AM can also reduce the “cradle-to-gate” environmental footprints of component manufacturing through avoidance of the tools, dies, and materials scrap associated with CM processes. Additionally, AM reduces waste by lowering human error in production.
9. **Reduced time to market:** Items can be fabricated as soon as the 3-D digital description of the part has been created, eliminating the need for expensive and time-consuming part tooling and prototype fabrication.
10. **Innovation:** AM enables designs with novel geometries that would be difficult or impossible to achieve using CM processes, which can improve a component’s engineering performance. Novel geometries enabled by AM technologies can also lead to performance and environmental benefits in a component’s product application.
11. **Part Consolidation:** The ability to design products with fewer, more complex parts, rather than a large number of simpler parts – is the most important of these benefits. Reducing the number of parts in an assembly immediately cuts the overhead associated with documentation and production planning and control. Also, fewer parts mean less time and labor is required for assembling the product, again contributing to a reduction in overall manufacturing costs. The “footprint” of the assembly line may also become smaller, further cutting costs.
12. **Lightweight:** With the elimination of tooling and the ability to create complex shapes, AM enables the design of parts that can often be made to the same functional specifications as conventional parts, but with less material.

13. Agility to manufacturing operations: Additive techniques enable rapid response to markets and create new production options outside of factories, such as mobile units that can be placed near the source of local materials. Spare parts can be produced on demand, reducing or eliminating the need for stockpiles and complex supply chains.

Disadvantages of Additive Manufacturing Technologies:

1. **Production cost is high** – With the use of techniques other than additive manufacturing, parts can be made faster and hence the extra time can lead to higher costs. Besides, high-quality additive manufacturing machines may cost high.
2. **Discontinuous production process** – To prevent economies of scale, parts can only be printed one at a time.
3. **Requires post-processing** – The surface finish and dimensional accuracy are of lower quality than other manufacturing methods.
4. **Slow build rates** – Some of the printers lay down material at a speed of one to five cubicinches per hour. Depending on the part needed the other manufacturing processes maybe higher.
5. **Considerable effort in application design and setting process parameters** – The material design needs vast knowledge and an additive manufacturing machine is needed to make quality parts.
6. **Poor mechanical properties** – Layering and multiple interfaces can cause defects in the product.
7. **Post-processing is needed** – Surface finish and dimensional accuracy may be of lower quality than other manufacturing methods.

Applications of Additive Manufacturing Technologies:

- Automotive applications
- Aerospace applications
- Biomedical applications
- Consumer goods applications
- Space applications
- Health care applications
- Artistic Industry
- Architectural Industry

Additive Manufacturing Processes:

Additive manufacturing processes are classified into seven areas on the basis of

These classifications have been developed by the ASTM International Technical Committee F42 on additive manufacturing technologies.

- Type of materials used
- Deposition technique, and
- The way the material is fused or solidified

The seven major additive manufacturing processes classified as per ASTM F42 are:

1. Photo polymerization
2. Material jetting
3. Binder jetting
4. Material extrusion
5. Powder Bed Fusion
6. Sheet Lamination
7. Direct Energy Deposition

